

Mountfield

- UK** TREND swimming pool roofing
- CZ** Zastřešení bazénu TREND
- FR** Toiture de piscine TREND
- NL** Afdekscherm TREND zwembad
- IT** Copertura piscina TREND
- DE** ÜBERDACHUNG DES SCHWIMMBADS TREND
- RUS** Павильон бассейна TREND
- SE** Pooltak TREND

- UK** MODULE ASSEMBLY GUIDE
- CZ** NÁVOD NA SESTAVENÍ MODULŮ
- FR** GUIDE DE MONTAGE DES MODULES
- NL** MONTAGEHANDLEIDING VOOR MODULEN
- IT** ISTRUZIONI PER ASSEMBLAGGIO MODULI
- DE** ANLEITUNG FÜR DIE MONTAGE DER MODULE
- RUS** ИНСТРУКЦИЯ ПО СБОРКЕ МОДУЛЕЙ
- SE** BRUKSANVISNING FÖR IHOPSÄTTNING AV MODULER



Czech

ČSN EN ISO 9001:2009



UK Table of Contents:

| | |
|---------------------------------|----|
| Handling | 3 |
| Package opening | 4 |
| Recommended tools | 5 |
| Material – photo | 6 |
| Diagram of material placement | 13 |
| Diagram of module frame | 14 |
| Module without door – PARTS | 22 |
| Module without doors – ASSEMBLY | 24 |
| Module with door – PARTS | 31 |
| Module with door – ASSEMBLY | 34 |

Appendices:

- > Material – table (pcs)
- > Assembly drawing

CZ Obsah:

| | |
|---------------------------|----|
| Manipulace | 3 |
| Otevření balení | 4 |
| Doporučené nářadí | 5 |
| Materiál – foto | 6 |
| Schéma umístění materiálu | 13 |
| Schéma konstrukce modulů | 15 |
| Modul bez dveří – DÍLY | 22 |
| Modul bez dveří – SLOŽENÍ | 24 |
| Modul s dveřmi – DÍLY | 31 |
| Modul s dveřmi – SLOŽENÍ | 34 |

Přílohy:

- > Materiál – tabulka (ks)
- > Montážní výkres

FR Sommaire:

| | |
|---------------------------------|----|
| Manutention | 3 |
| Déballage | 4 |
| Outils recommandés | 5 |
| Pièces – photos | 6 |
| Schéma d'emplacement des pièces | 13 |
| Schéma de montage des modules | 16 |
| Module sans porte – PIÈCES | 22 |
| Module sans porte – MONTAGE | 24 |
| Module avec porte – PIÈCES | 31 |
| Module avec porte – MONTAGE | 34 |

Annexes :

- > Pièces – Tableau (pce)
- > Plan de montage

NL Inhoud:

| | |
|------------------------------------|----|
| Hantering | 3 |
| Openen verpakking | 4 |
| Aanbevolen gereedschap | 5 |
| Materiaal – foto's | 6 |
| Schema plaatsing materiaal | 13 |
| Schema constructie modulen | 17 |
| Module zonder deur – DELEN | 22 |
| Module zonder deur – SAMENSTELLING | 24 |
| Module met deur – DELEN | 31 |
| Module met deur – SAMENSTELLING | 34 |

Bijlagen:

- > Materiaal – tabel (st.)
- > Montagetekening

IT Indice:

| | |
|---------------------------------------|----|
| Manipolazione | 3 |
| Apertura imballo | 4 |
| Utensili consigliati | 5 |
| Materiale – foto | 6 |
| Schema posizionamento materiale | 13 |
| Schema assemblaggio moduli | 18 |
| Modulo senza sportello – COMPONENTI | 22 |
| Modulo senza sportello – ASSEMBLAGGIO | 24 |
| Modulo con sportello – COMPONENTI | 31 |
| Modulo con sportello – ASSEMBLAGGIO | 34 |

Alligato:

- > Materiale – tabella (pz.)
- > Disegno di montaggio

DE Inhalt:

| | |
|-------------------------------------|----|
| Handhabung | 3 |
| Öffnen einer Packung | 4 |
| Empfohlene Werkzeuge | 5 |
| Material – Foto | 6 |
| Schema der Materialanordnung | 13 |
| Schema der Konstruktion der Module | 19 |
| Modul ohne Tür – TEILE | 22 |
| Modul ohne Tür – ZUSAMMENSETZUNG | 24 |
| Modul mit der Tür – TEILE | 31 |
| Modul mit der Tür – ZUSAMMENSETZUNG | 34 |

Beilagen:

- > Material – Tabelle (Stck)
- > Montagezeichnung

RUS Содержание:

| | |
|---------------------------------|----|
| Манипуляция | 3 |
| Устранение упаковки | 4 |
| Рекомендуемый инструмент | 5 |
| Материал – фото | 6 |
| Схема размещения материала | 13 |
| Схема конструкции модулей | 20 |
| Модуль без дверей – ДЕТАЛИ | 22 |
| Модуль без дверей – СОСТАВЛЕНИЕ | 24 |
| Модуль с дверьми – ДЕТАЛИ | 31 |
| Модуль с дверьми – СОСТАВЛЕНИЕ | 34 |

Приложение:

- > Материал – таблица (шт.)
- > Сборочный чертеж

SE Innehåll:

| | |
|--------------------------------|----|
| Hantering | 3 |
| Uppackning | 4 |
| Rekommenderade verktyg | 5 |
| Material – bilder | 6 |
| Placering av material | 13 |
| Konstruktionsschema av moduler | 21 |
| Modul utan dörr – DELAR | 22 |
| Modul utan dörr – IHOPSÄTTNING | 24 |
| Modul med dörr – DELAR | 31 |
| Modul med dörr – IHOPSÄTTNING | 34 |

Bilagor:

- > Material – tabell (st.)
- > Monteringsritning



UK TO BE ONLY HANDLED
IN UPRIGHT POSITION! FRAGILE!

CZ MANIPULACE POUZE
VE SVISLÉ POLOZE! KŘEHKÉ!

FR A NE MANIPULER UNIQUEMENT QU'EN
POSITION VERTICALE! FRAGILE!

NL HANTEREN SLECHTS
IN VERTICALE POSITIE! BROOS!

IT FRAGILE! MANIPOLARE SOLO
IN POSIZIONE VERTICALE!

DE HANDHABUNG NUR IN DER VERTI-
KALEN POSITION! ZERBRECHLICH!

RUS МАНИПУЛЯЦИЯ ТОЛЬКО В ВЕРТИ-
КАЛЬНОМ ПОЛОЖЕНИИ! ХРУПКОЕ!

SE HANERING SKALL SKE BARA
I UPPRÄTT LÄGE! FRAGIL!

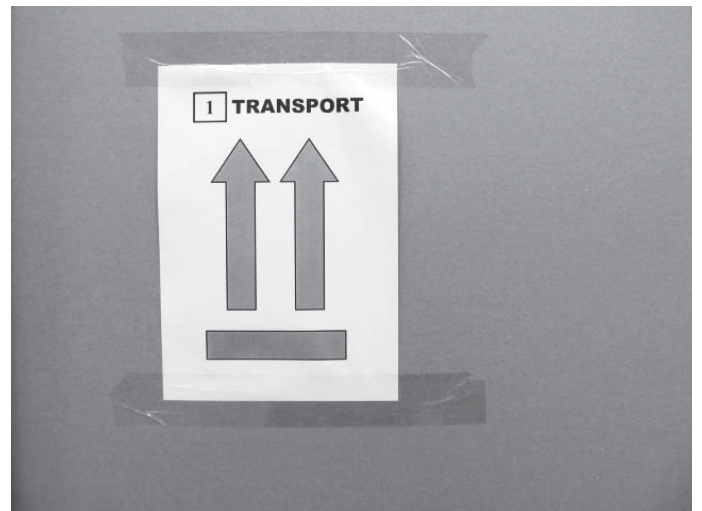

TREND

Package opening / Otevření balení / Déballage
Openen verpakking / Öffnen einer Packung
Öffnen einer Packung / Устранение упаковки / Урраскнинг

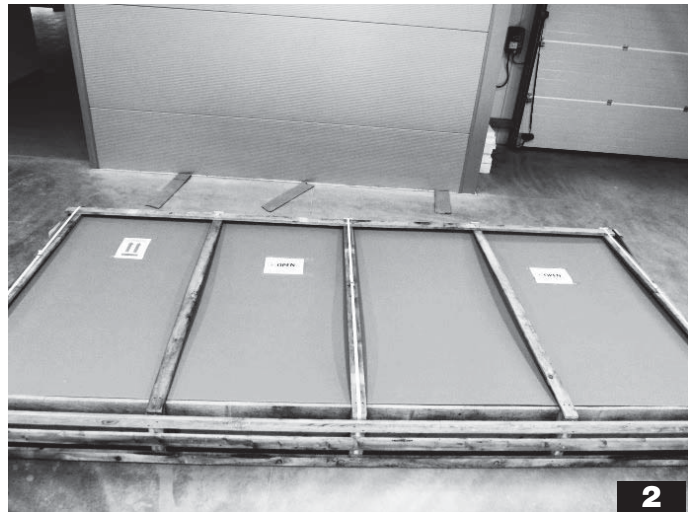

Recommended tools / Doporučené nářadí
 Outils recommandés / Aanbevolen gereedschap
 Utensili consigliati / Empfohlene werkzeuge
 Рекомендуемый инструмент / Rekommenderade verktyg

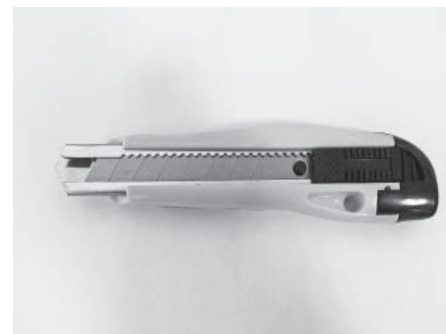

- UK** Extended adapter for AKU - 9 cm
- CZ** Prodloužený nástavec na AKU - 9 cm
- FR** Rallonge étendue AKU - 9 cm
- NL** Verlengd opzetstuk voor AKU- 9 cm
- IT** Prolunga per AKU - 9 cm
- DE** Verlängerer aufsatz für aku - 9 cm
- RUS** Удлинитель для АКУ - 9 см
- SE** Bitsfäste för skruvdragare - 9 cm

- UK** BIT - hex key 5 mm
- CZ** BIT - imbus 5 mm
- FR** BIT - allen 5 mm
- NL** BIT - INBUS 5 mm
- IT** BIT - a brugola 5 mm
- DE** BIT - imbusschraube 5 mm
- RUS** BIT - внутренний шестигран. 5 мм
- SE** BITS - insex 5mm

- UK** BIT - PH 2
- CZ** BIT - PH 2
- FR** BIT - PH 2
- NL** BIT - PH 2
- IT** BIT - PH 2
- DE** BIT - PH 2
- RUS** BIT - PH 2
- SE** BITS - PH 2



- UK** BIT - PZ 2
- CZ** BIT - PZ 2
- FR** BIT - PZ 2
- NL** BIT - PZ 2
- IT** BIT - PZ 2
- DE** BIT - PZ 2
- RUS** BIT - PZ 2
- SE** BITS - PZ 2

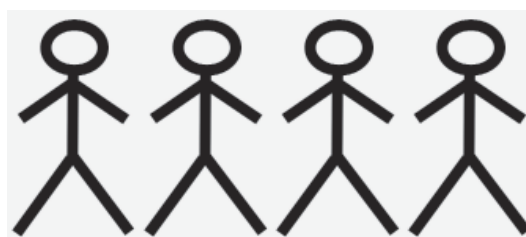

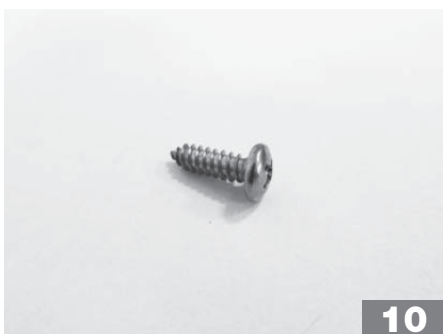
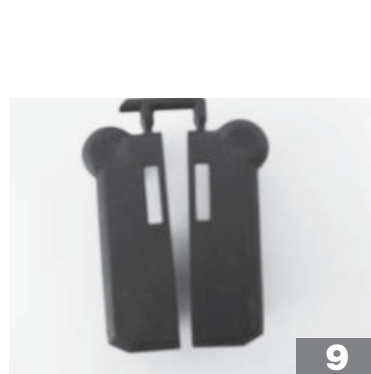
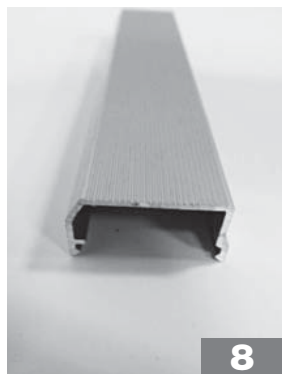
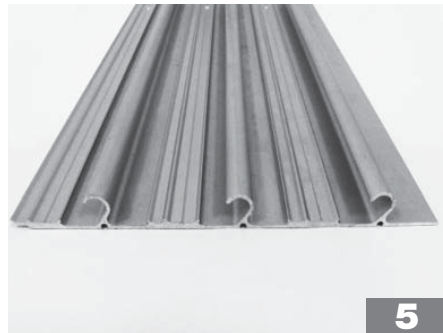
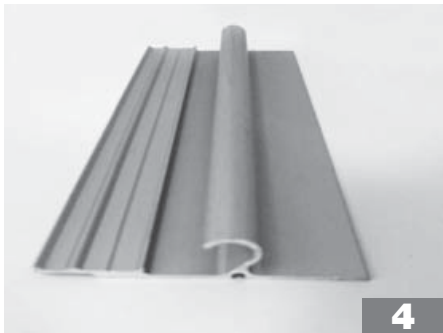

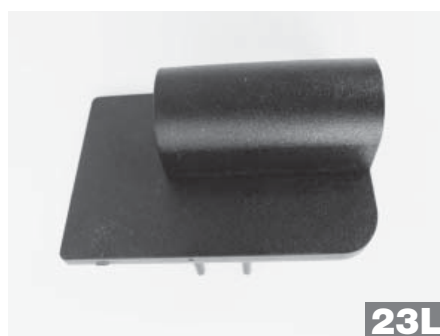

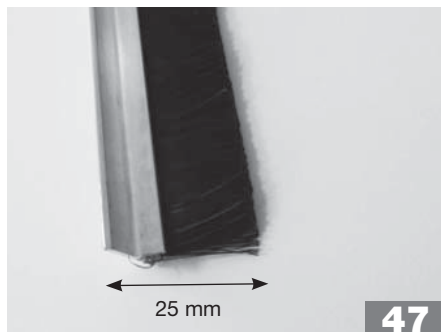
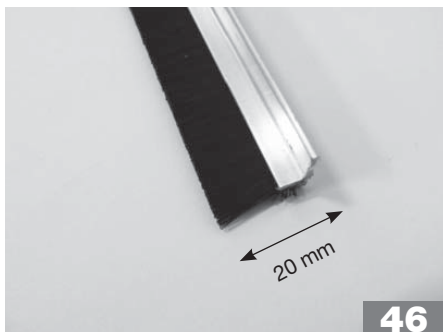
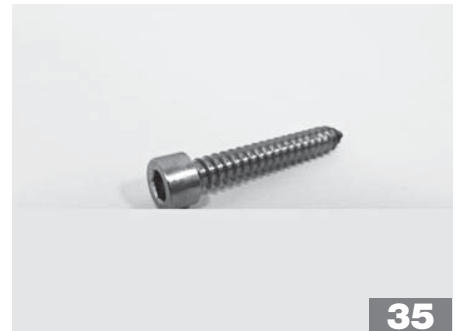
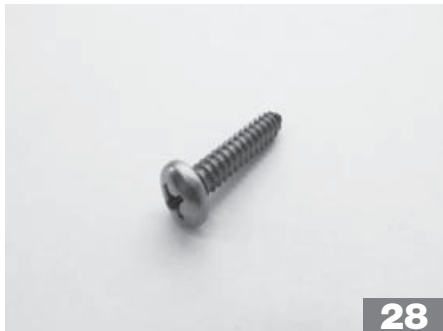



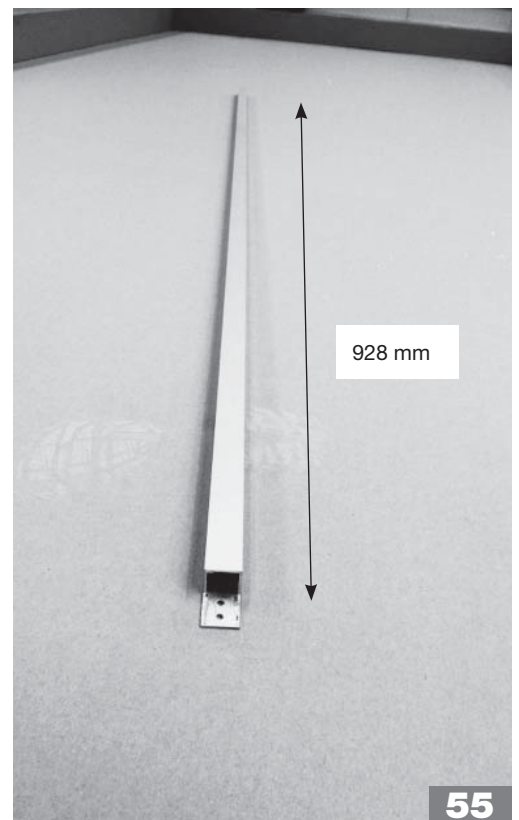
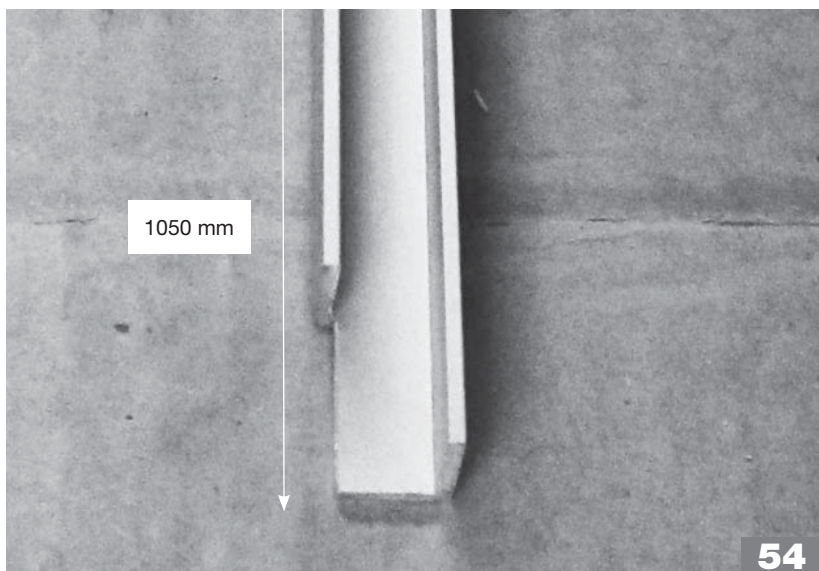
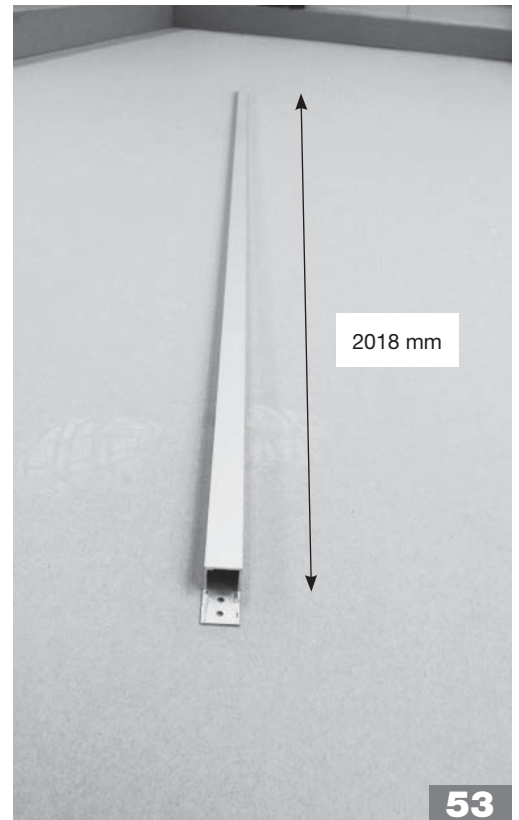
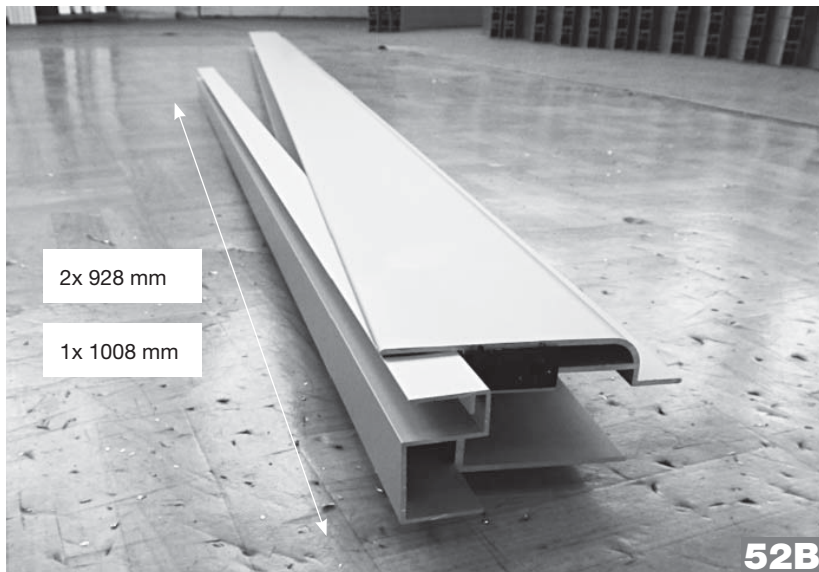

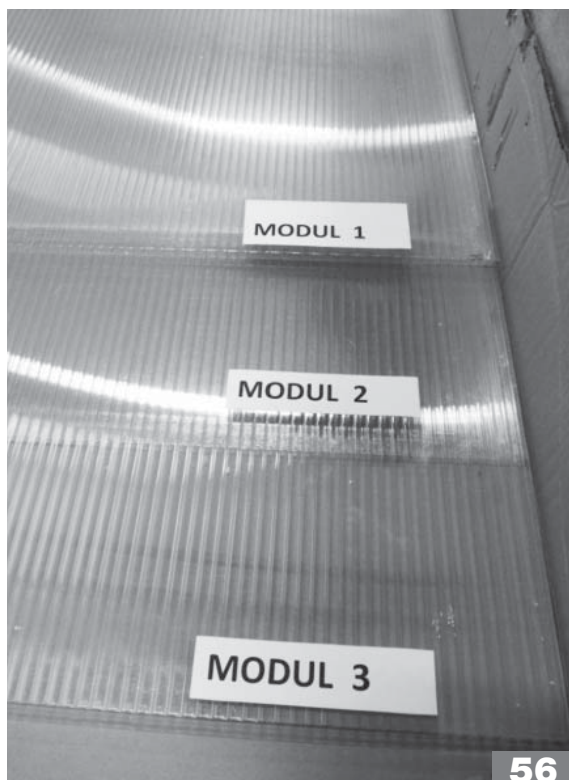
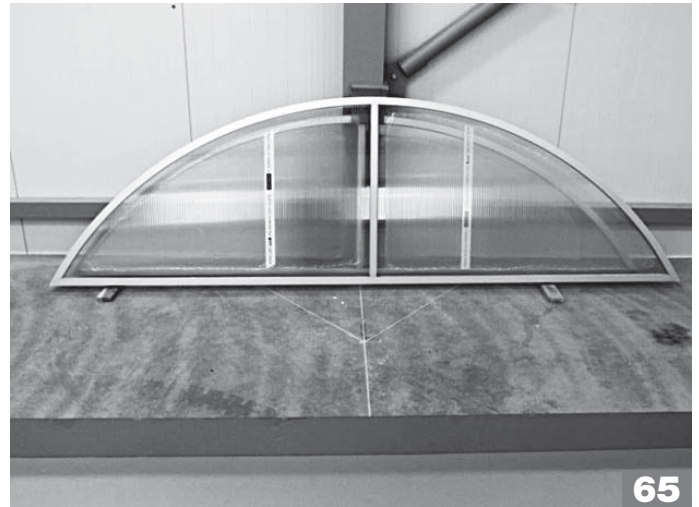
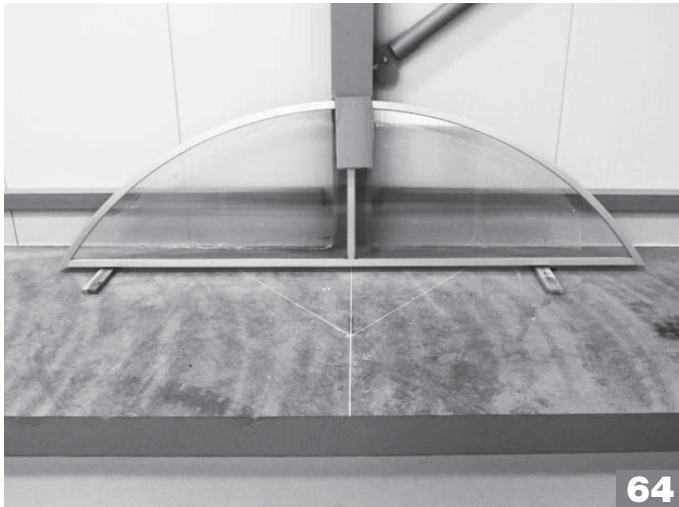

UK PC boards for modules without door

CZ Desky PC pro moduly bez dveří

FR Panneaux PC pour les modules sans porte

NL PC panelen voor de modulen zonder de deur

IT Tavole PC per moduli senza sportello

DE PC Platten für Module ohne Tür

RUS Листы PC (поликарбонатные) для модулей без дверей

SE PC-paneler för moduler utan dörr

UK PC boards for modules with door

CZ Desky PC pro moduly s dveřmi

FR Panneaux PC pour le module avec porte

NL PC panelen voor de modulen met de deur

IT Tavole PC per moduli con sportello

DE PC Platten für Module mit der Tür

RUS Листы PC для модуля с дверьми

SE PC-paneler för modul med dörr

1x 59

UK 6 mm thick PC board - DOOR

CZ deska PC tl. 6 mm - DVEŘE

FR panneau PC ép. 6 mm - PORTE

NL PC paneel dikte 6 mm - DEUR

IT tavola PC spess. 6mm - SPORTELLLO

DE PC Platte St. 6mm - TÜR

RUS лист PC толщ. 6мм - ДВЕРИ

SE PC-skivan tjockl. 6mm - DÖRR

1x 58

UK 10 mm thick PC board - against the door

CZ deska PC tl. 10mm - proti dveřím

FR panneau PC ép. 10 mm - contre la porte

NL PC paneel - dikte 10 mm - tegen de deur

IT tavola PC spess. 10mm - contro sportello

DE PC Platte St. 10mm - gegen die Tür

RUS лист PC толщ. 10мм - напротив дверям

SE PC-skivan tjockl. 10mm - mittemot dörr

1x 57

UK 10 mm thick PC board - beside the door

CZ deska PC tl. 10mm - vedle dveří

FR panneau PC ép. 10 mm - à côté de la porte

NL PC paneel - dikte 10 mm - naast de deur

IT tavola PC spess. 10mm - accanto sportello

DE PC Platte St. 10mm neben der Tür

RUS лист PC толщ. 10мм - рядом с дверьми

SE PC-skivan tjockl. 10mm - bredvid dörr

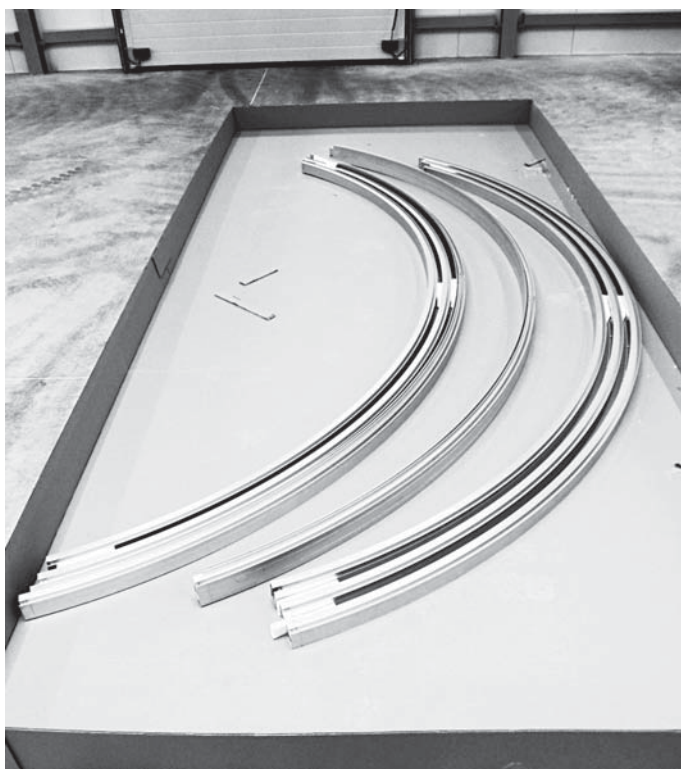

UK Module ARCHES - see the Appendix

CZ OBLOUKY modulů - viz příloha

FR ARCS des modules - voir l'annexe

NL BOGEN van de modulen - zie bijlage

IT ARCHI moduli - si veda l'allegato

DE BÖGEN der Module-sieh Beilage

RUS АРКИ модулей - см. приложение

SE VALV - se bilaga

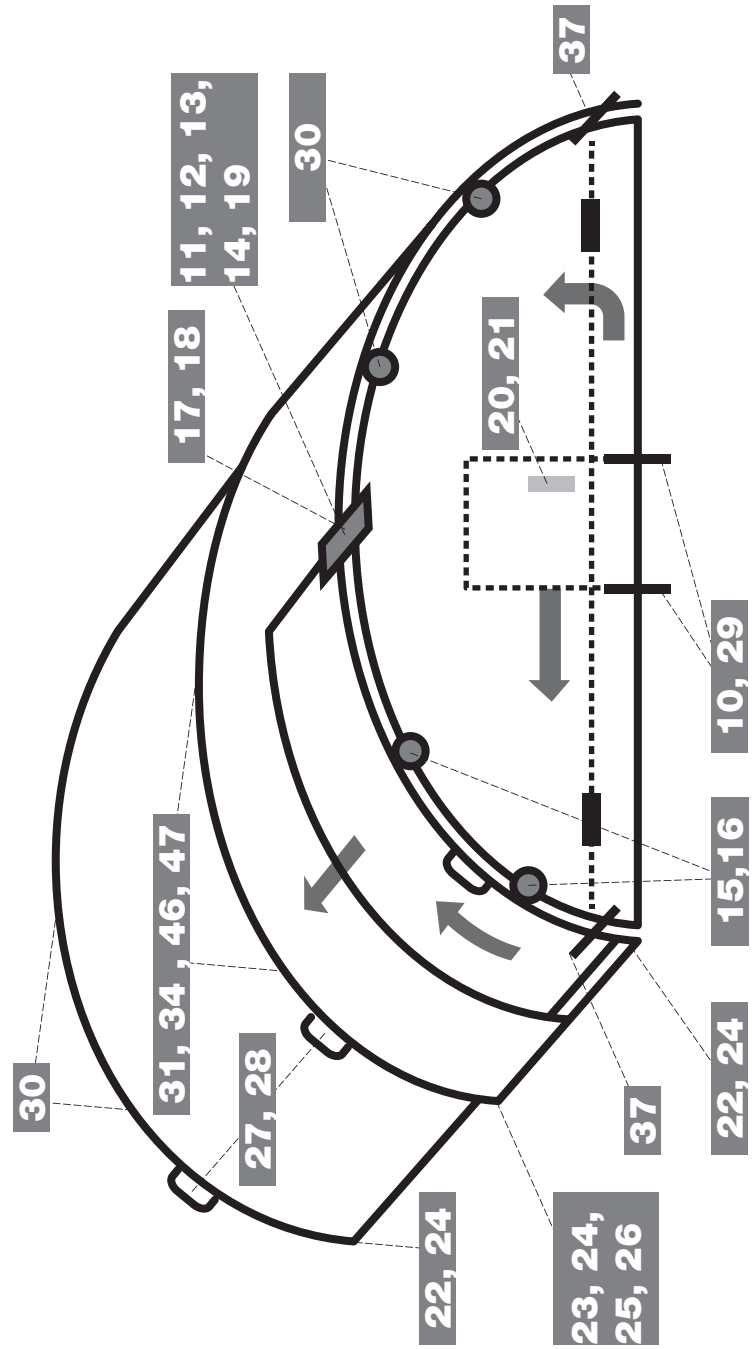
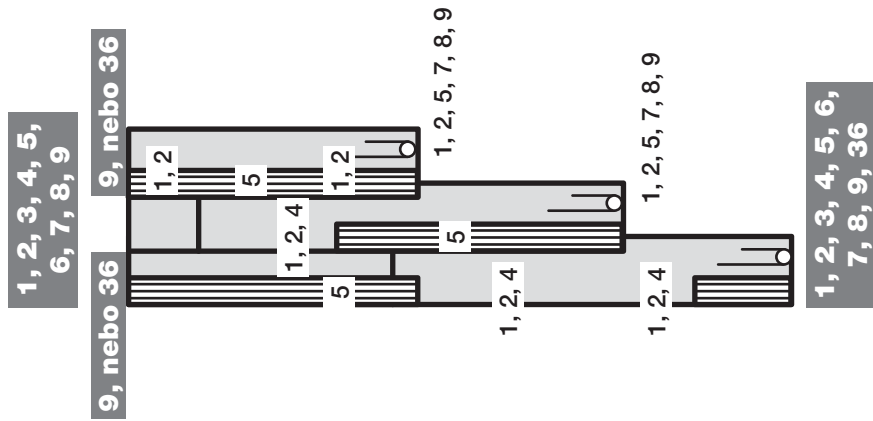

A diagram of the frame of roofing modules TREND - the positioning of arches in individual modules

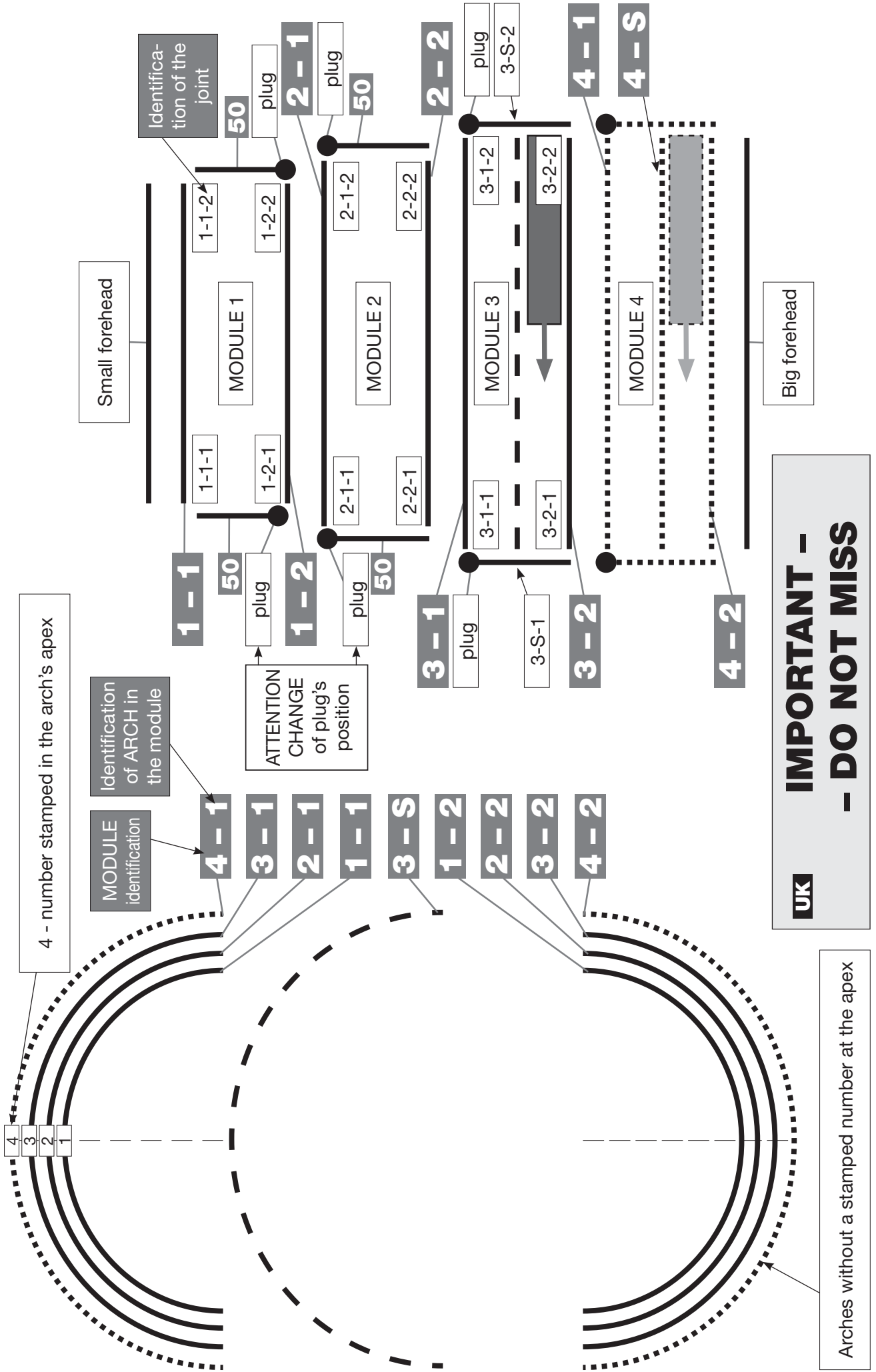

FR Schéma de montage des modules de la toiture de la piscine TREND - Emplacement des arcs dans les différents modules

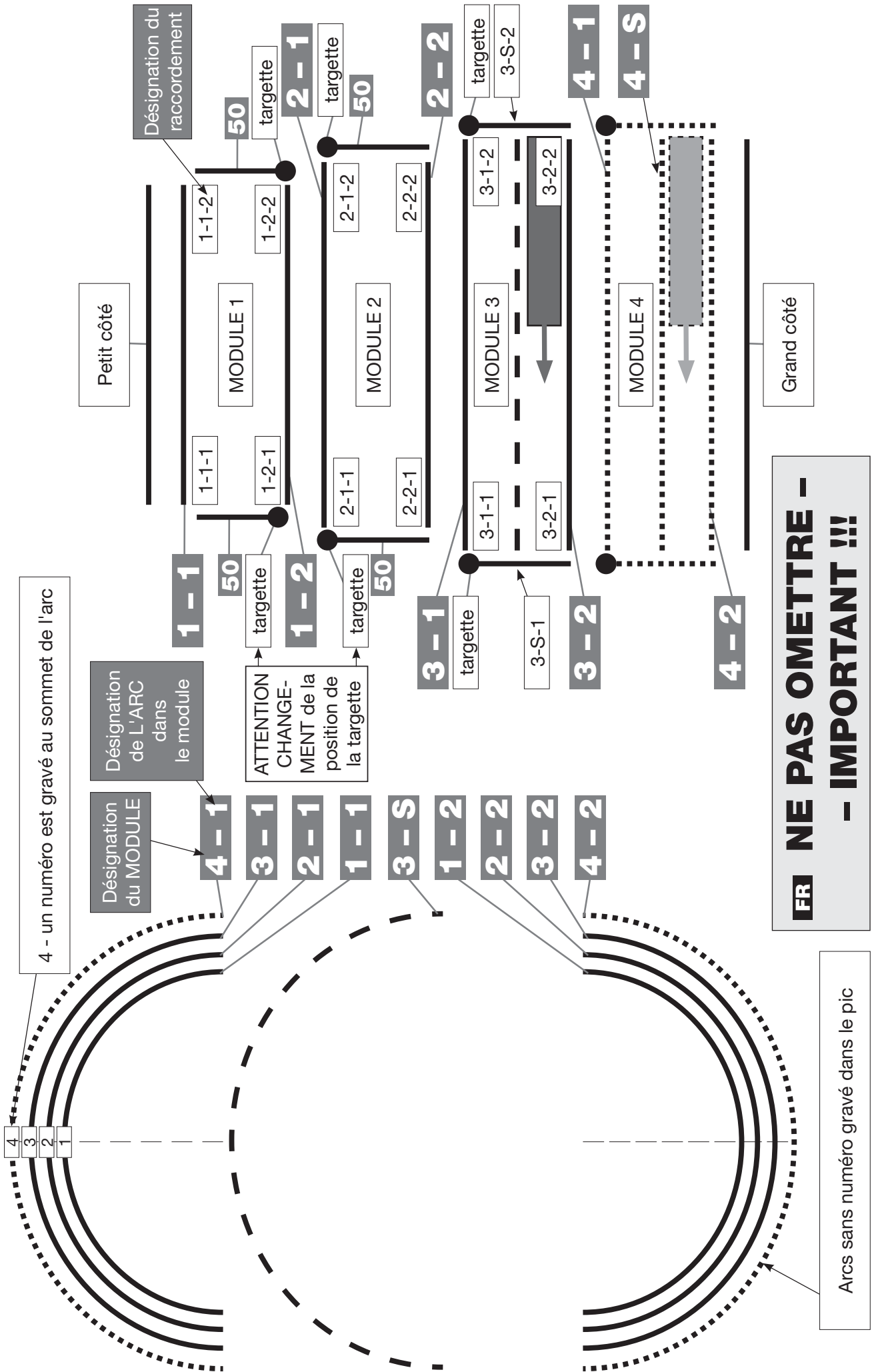

NL Schema constructie van afdekscherm van het TREND zwembad – plaatsing van de bogen in aparte modules

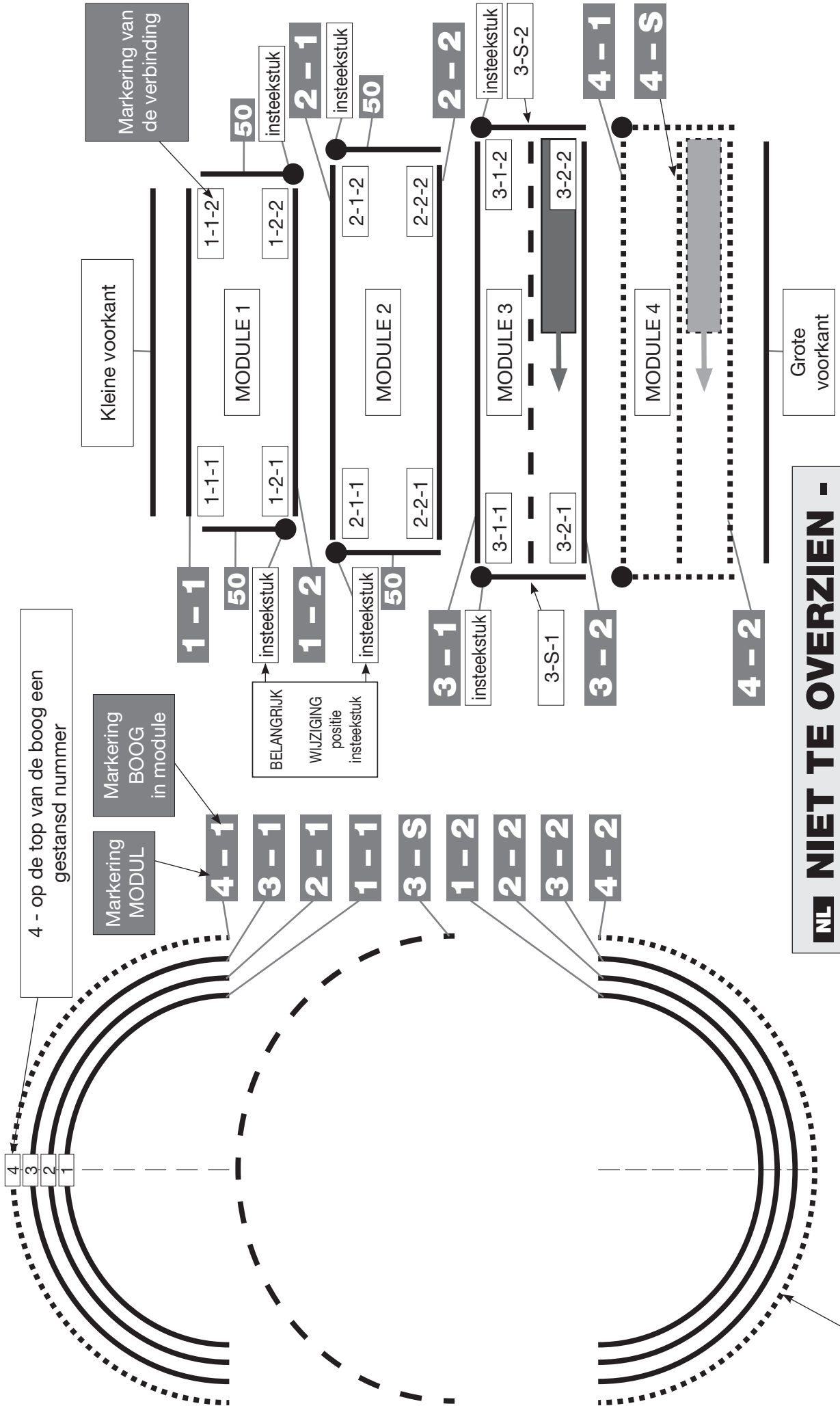

NL NIET TE OVERZIEN - BELANGRIJK!!!

De bogen zonder het gestansde nummer op de top

IT Schema di assemblaggio moduli della copertura piscina TREND - posizionamento di archi nei singoli moduli

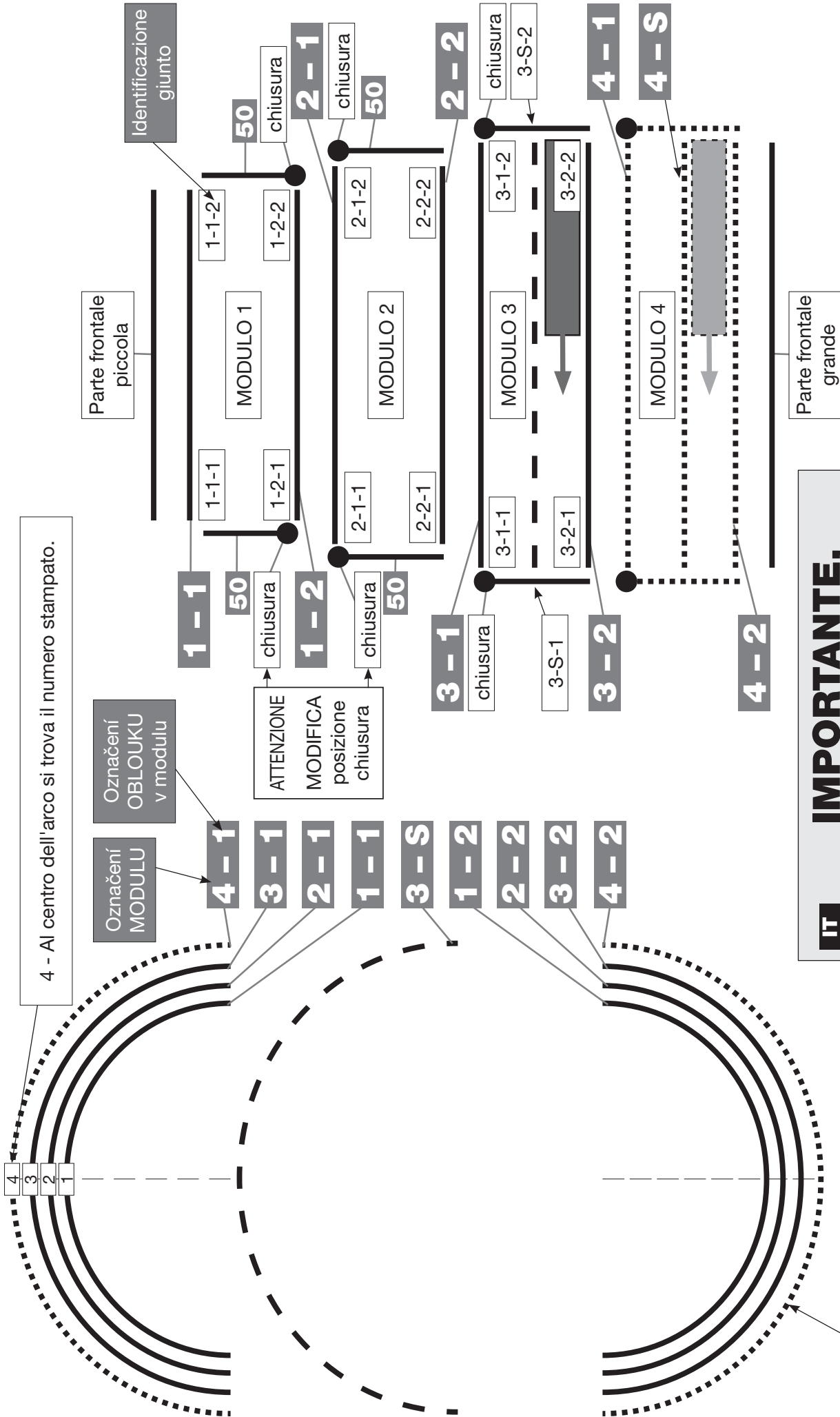

DE Aufbau-Schema der Module für die Schwimmbad-Überdachung TREND - Lage der Bögen in einzelnen Modulen.

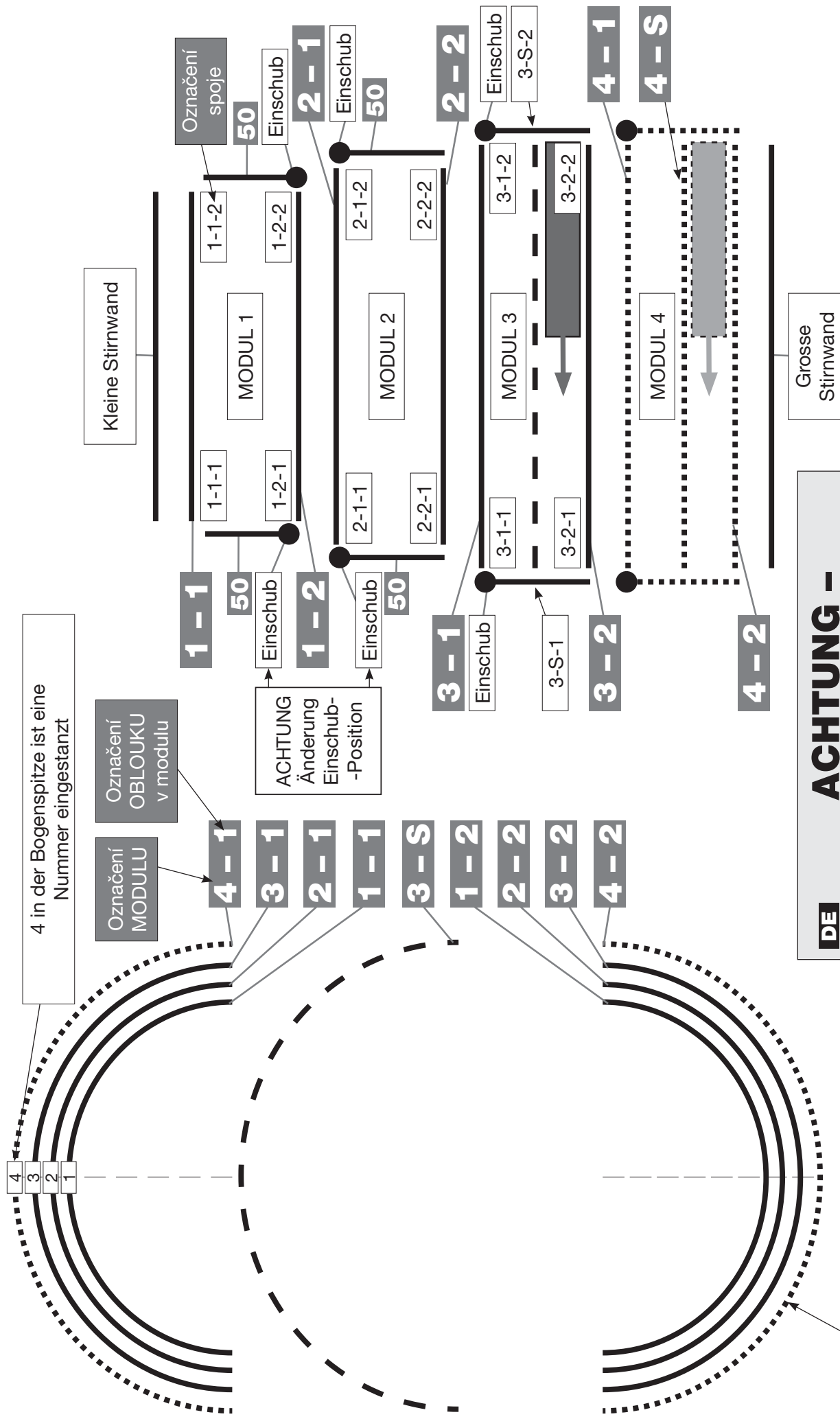

DE **ACHTUNG -**
- WICHTIG !!!

Bögen ohne ausgezante Nummer in der Spitze

SE

Konstruktionsschema av pooltak TREND – placering av valven i enskilda moduler.

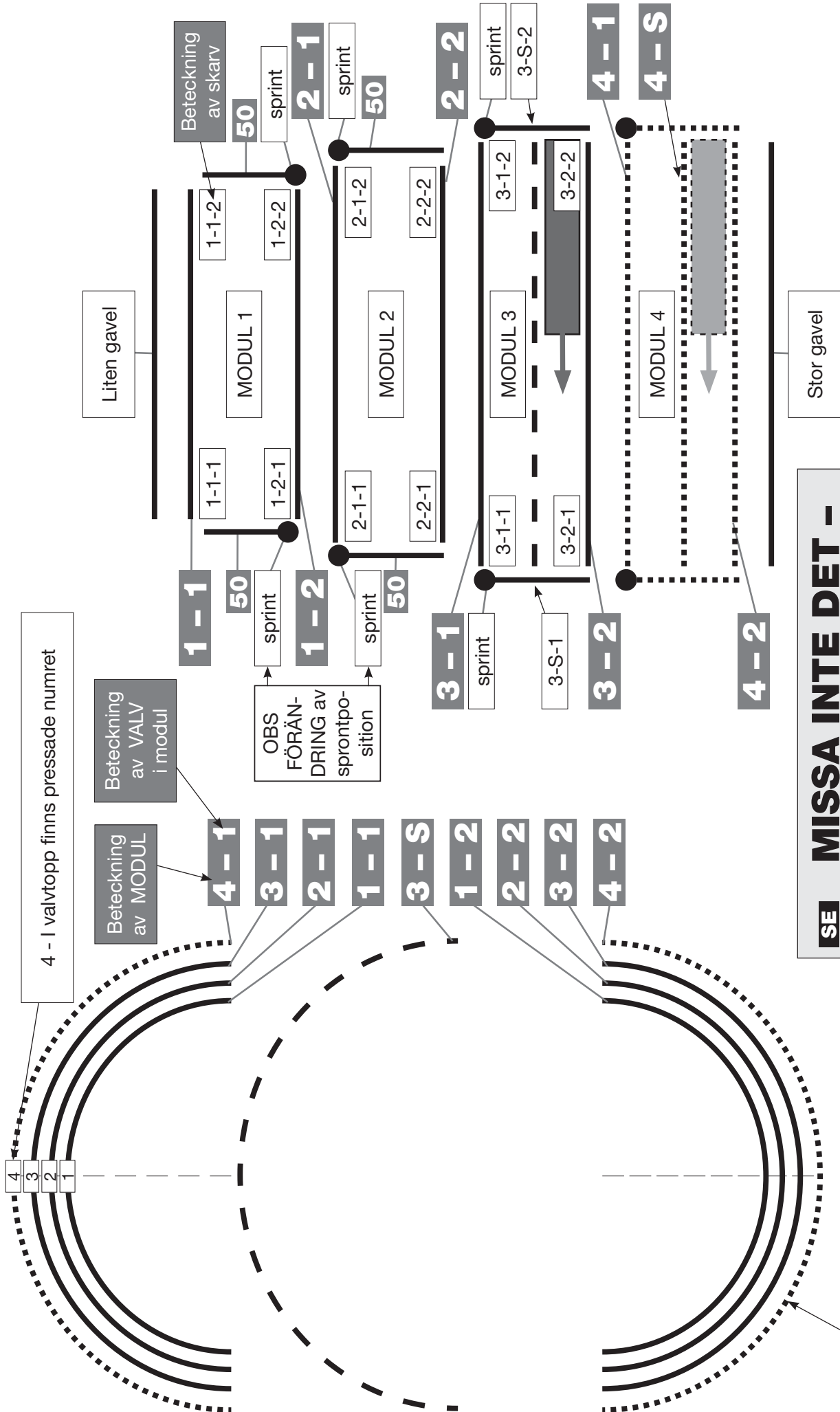

SE **MISSA INTE DET -
- VIKTIGT !!!**

MODULE – without door / MODUL – bez dveří
 MODULE – sans porter / MODULE – zonder deur
 MODULO – senza sportello / MODUL – ohne Tür
 МОДУЛЬ – без дверей / MODUL – utan dörr

UK PARTS

CZ DÍLY

FR PIÈCES

NL DELEN

IT Componenti

DE TEILE

RUS ДЕТАЛИ

SE DELAR

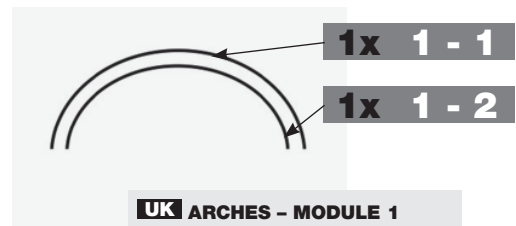
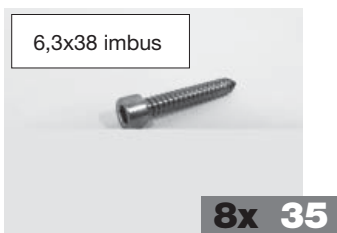
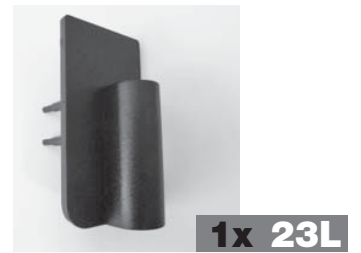

UK ARCHES - MODULE 1
CZ OBLOUKY - MODUL 1
FR ARCS - MODULE 1
NL BOGEN - MODULE 1
IT ARCHI - MODULO 1
DE BÖGEN- MODUL 1
RUS АРКИ - МОДУЛЬ 1
SE VALV - MODUL 1

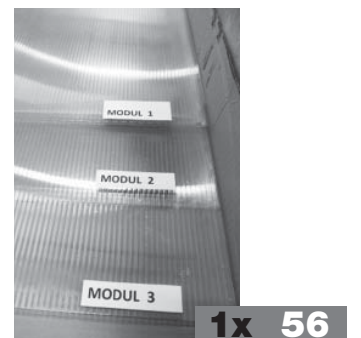
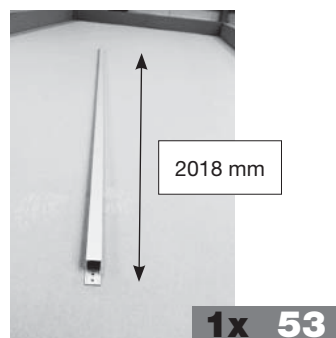
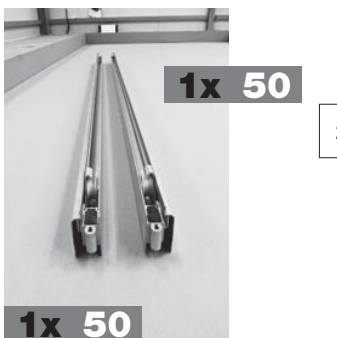

MODULE – without door / MODUL – bez dveří
MODULE – sans porter / MODULE – zonder deur
MODULO – senza sportello / MODUL – ohne Tür
МОДУЛЬ – без дверей / MODUL – utan dörr

TREND

UK Before assembly, remove the protective foil from PC boards!

CZ Před montáží nutno odstranit z desek PC ochranné folie !

FR Il est nécessaire avant montage d'enlever les feuilles de protection recouvrant les plaques PC !

NL Voor de montage moeten de PC-beschermfoliën van de panelen verwijderd worden!

IT Rimuovere la pellicola protettiva dalle tavole in PC ancor prima dell'assemblaggio!

DE Vor der Montage muss die Schutzfolie aus den PC-Platten entfernt werden!

RUS Перед сборкой с листов PC (поликарбонатных) надо снять защитную пленку !

SE Ta bort PC-skyddsfolien från skivor innan monteringen!

UK For positioning of arches in individual modules see the Appendix to the Assembly Guide!

CZ Umístění oblouků v jednotlivých modulech viz příloha návodu !

FR Se reporter à l'annexe du guide de montage pour vérifier le positionnement des arcs dans les différents modules !

NL Het plaatsen van de bogen in afzonderlijke modulen - zie bijlage van de handleiding!

IT Per il posizionamento degli archi nei singoli moduli si veda l'Allegato al Libretto d'uso!

DE Lage der Bögen in einzelnen Modulen, siehe Anhang der Anleitung!

RUS Размещение арок в отдельных модулях - см. приложение инструкции !

SE Placering a valv i enskilda moduler se bilagan till bruksanvisningen!

UK Arch Number 1-1-1 (= module number – identification of arch in the module – identification of joint)

CZ Číslo oblouku 1-1-1 (=číslo modulu – označení oblouku v modulu – označení spoje)

FR Le numero de l'arc 1-1-1 (= numéro du module – désignation de l'arc dans le module – désignation de la jonction)

NL Het boognummer 1-1-1 (= modulnr. – markering van de boog in de module – markering van de verbinding)

IT Numero arco 1-1-1 (= numero del modulo – identificazione dell'arco nel modulo – identificazione del giunto)

DE Bogen-Nummer 1-1-1 (= Modulnummer - Bezeichnung des Bogens im Modul - Bezeichnung der Verbindung)

RUS Номер арки 1-1-1 (=номер модуля – обозначение арки в модуле – обозначение соединения)

SE Valvnummer 1-1-1 (=modulnummer – beteckning av valv i modul – beteckning av skarv)

UK The assembly drawing providing a precise specification of the supplied roofing forms an integral part of the Assembly Guide (see the Appendices)!

CZ Nedílnou součástí návodu je montážní výkres (viz přílohy), který přesně specifikuje dodané zastřešení !

FR Le plan de montage fait partie inséparable du guide de montage (voir les annexes), lequel spécifie précisément la toiture livrée !

NL Een integraal onderdeel van de handleiding is de montagekening (zie bijlagen) met exacte specificatie van de geleverde afdekking!

IT Il disegno di montaggio che rappresenta esattamente la copertura fornita fa parte del Libretto d'uso (si vedano gli allegati)!

DE Montagezeichnung ist ein Bestandteil der Anleitung (siehe Anhänge) und gibt genau gelieferte Überdachung an!

RUS Неотъемлемой составной частью инструкции является сборочный чертеж (см. приложения), который точно специфицирует поставленный павильон !

SE Monteringsritningen är en del av bruksanvisningen (se bilagor) som exakt specificerar det levererade taket!

UK ASSEMBLY

CZ SLOŽENÍ

FR COMPOSITION

NL SAMENSTELLING

IT ASSEMBLAGGIO

DE AUFBAU

RUS СОСТАВЛЕНИЕ

SE IHOPSÄTTNING

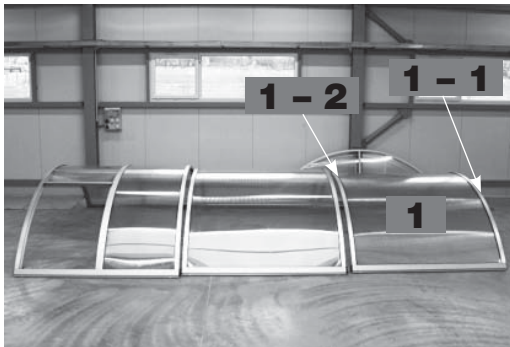

UK Before assembly, remove the protective foil from PC boards!

CZ Před montáží nutno odstranit z desek PC ochranné fólie!

FR Il est nécessaire avant montage d'enlever les feuilles de protection recouvrant les plaques PC!

NL Voor de montage moeten de PC-bescherffoliën van de panelen verwijderd worden!

IT Rimuovere la pellicola protettiva dalle tavole in PC ancor prima dell'assemblaggio!

DE Vor der Montage muss die Schutzfolie aus den PC-Platten entfernt werden!

RUS Перед сборкой с листов PC (поликарбонатных) надо снять защитную пленку!

SE Ta bort PC-skyddsfolien från skivor innan montering!

UK ARCH 1 - 1 **IT** ARCO 1 - 1
CZ OBLOUK 1 - 1 **DE** BOGEN 1 - 1
FR ARC 1 - 1 **RUS** АРКА 1 - 1
NL BOOG 1 - 1 **SE** VALV 1 - 1

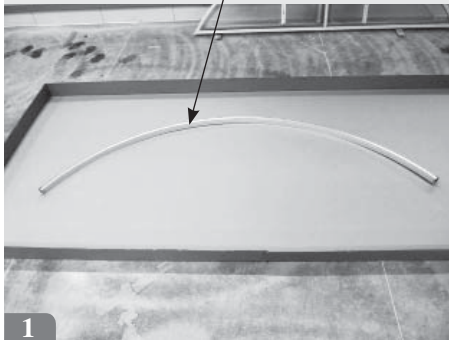

UK ARCH 1 - 2 **IT** ARCO 1 - 2
CZ OBLOUK 1 - 2 **DE** BOGEN 1 - 2
FR ARC 1 - 2 **RUS** АРКА 1 - 2
NL BOOG 1 - 2 **SE** VALV 1 - 2

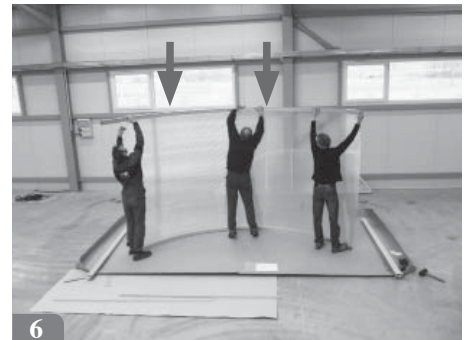

MODULE – without door / MODUL – bez dveří
 MODULE – sans porter / MODULE – zonder deur
 MODULO – senza sportello / MODUL – ohne Tür
 МОДУЛЬ – без дверей / MODUL – utan dörr

TREND

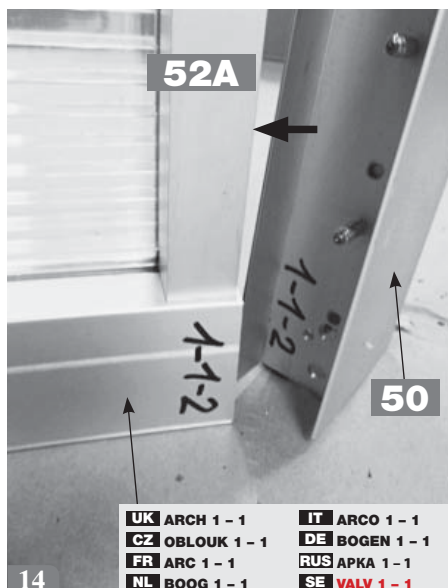
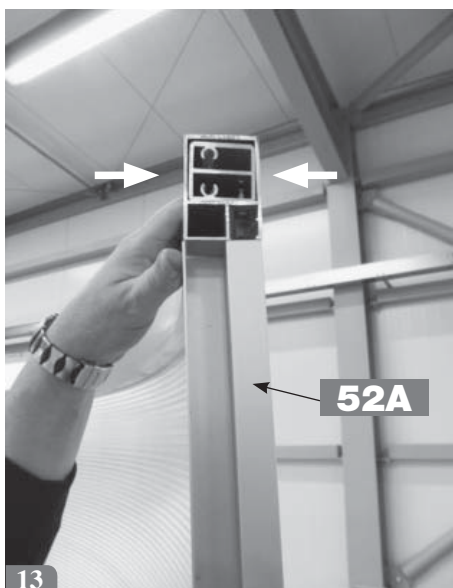
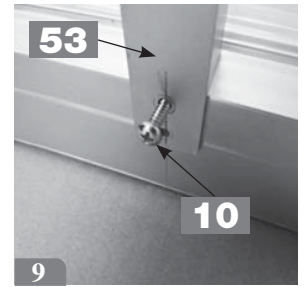

| | |
|------------------------|-----------------------|
| UK ARCH 1 - 2 | IT ARCO 1 - 2 |
| CZ OBLOUK 1 - 2 | DE BOGEN 1 - 2 |
| FR ARC 1 - 2 | RUS АРКА 1 - 2 |
| NL BOOG 1 - 2 | SE VALV 1 - 2 |

| | |
|------------------------|-----------------------|
| UK ARCH 1 - 1 | IT ARCO 1 - 1 |
| CZ OBLOUK 1 - 1 | DE BOGEN 1 - 1 |
| FR ARC 1 - 1 | RUS АРКА 1 - 1 |
| NL BOOG 1 - 1 | SE VALV 1 - 1 |

MODULE – without door / MODUL – bez dveří
MODULE – sans porter / MODULE – zonder deur
MODULO – senza sportello / MODUL – ohne Tür
МОДУЛЬ – без дверей / MODUL – utan dörr

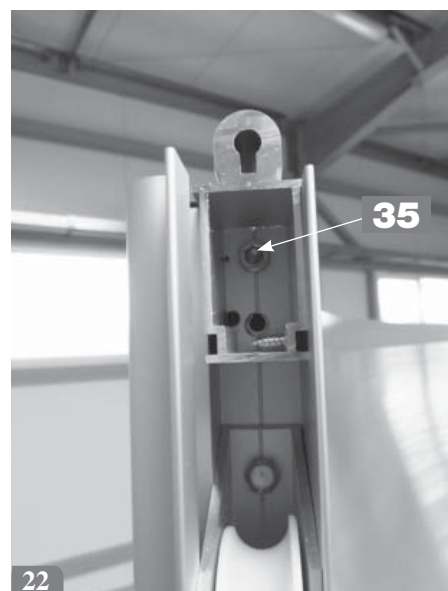
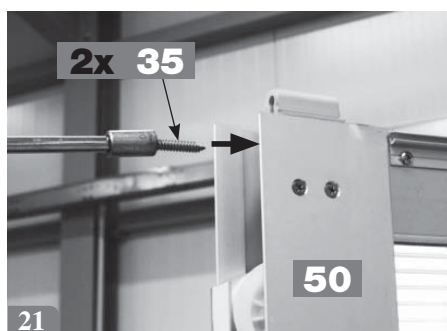
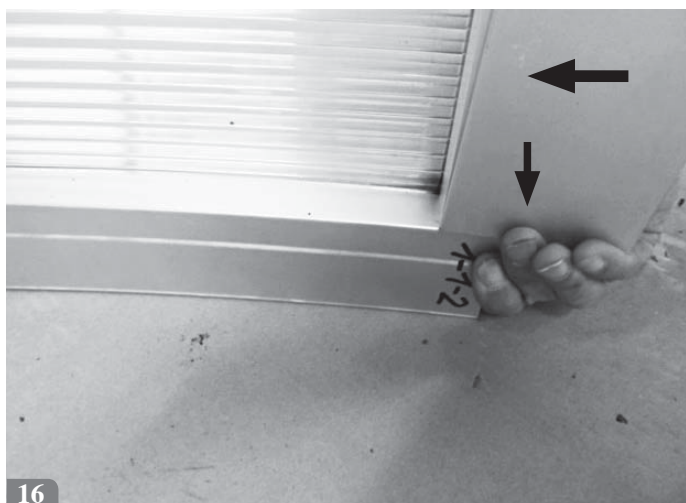

MODULE – without door / MODUL – bez dveří
 MODULE – sans porter / MODULE – zonder deur
 MODULO – senza sportello / MODUL – ohne Tür
 МОДУЛЬ – без дверей / MODUL – utan dörr

TREND

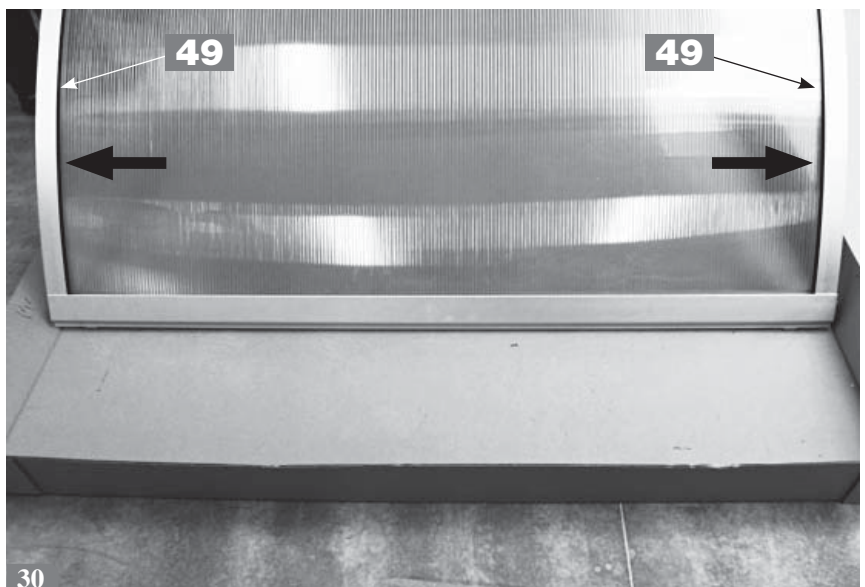
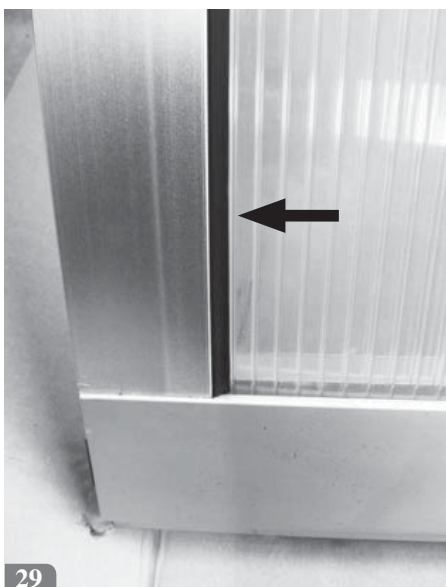
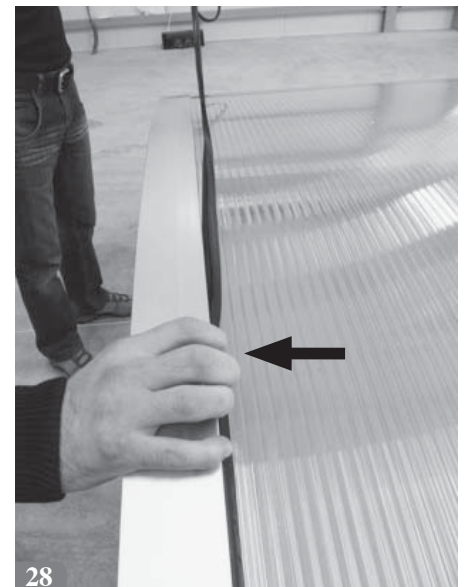
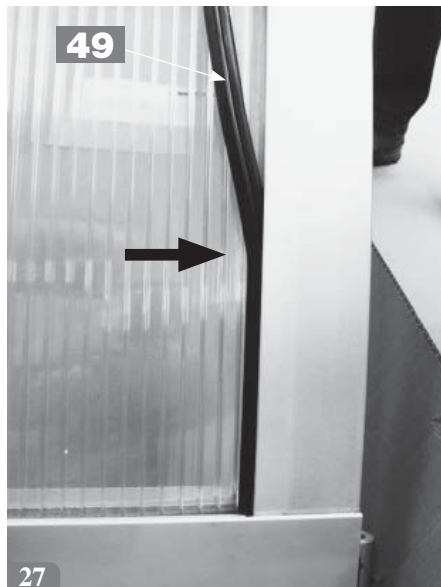
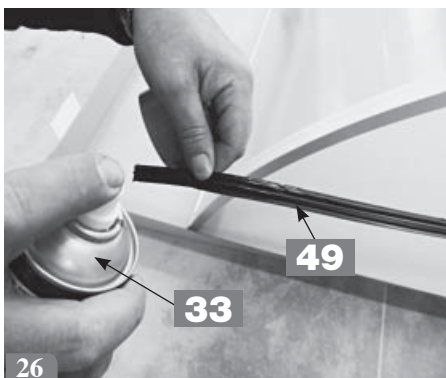
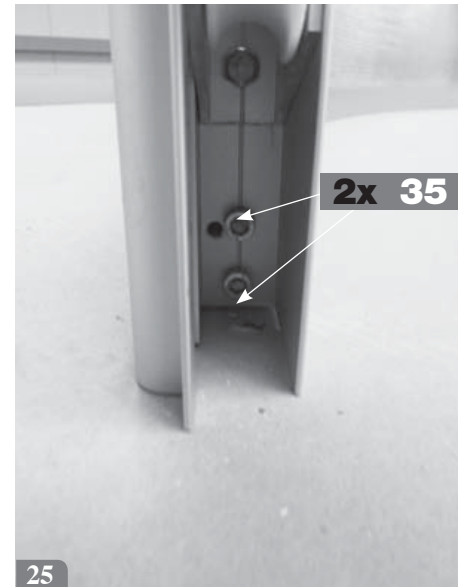
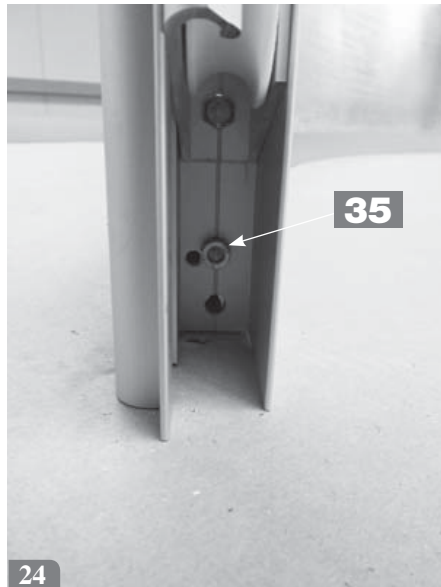
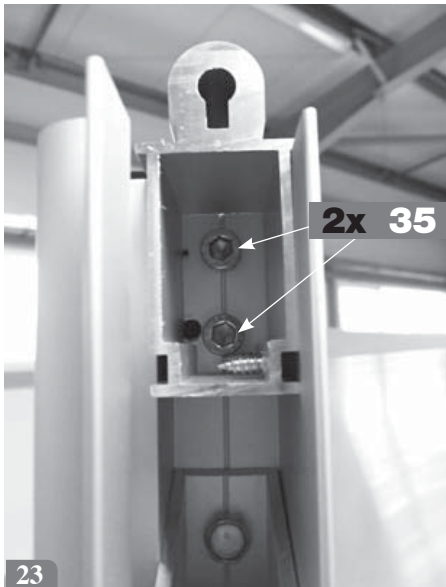

MODULE – without door / MODUL – bez dveří
MODULE – sans porter / MODULE – zonder deur
MODULO – senza sportello / MODUL – ohne Tür
МОДУЛЬ – без дверей / MODUL – utan dörr

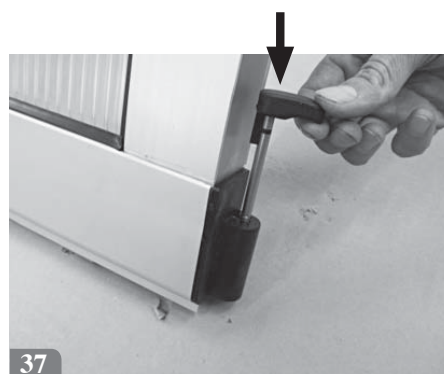
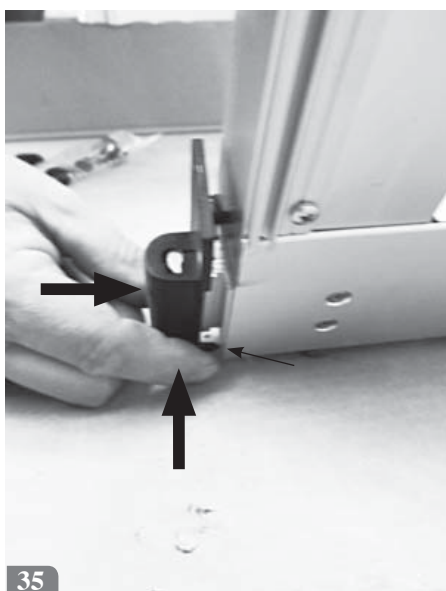
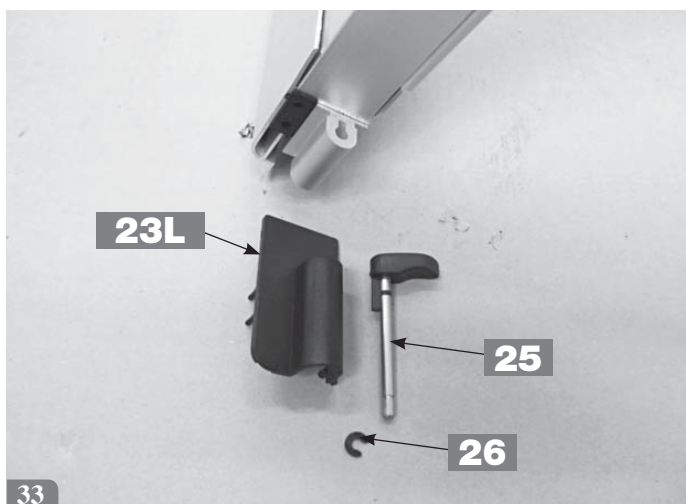
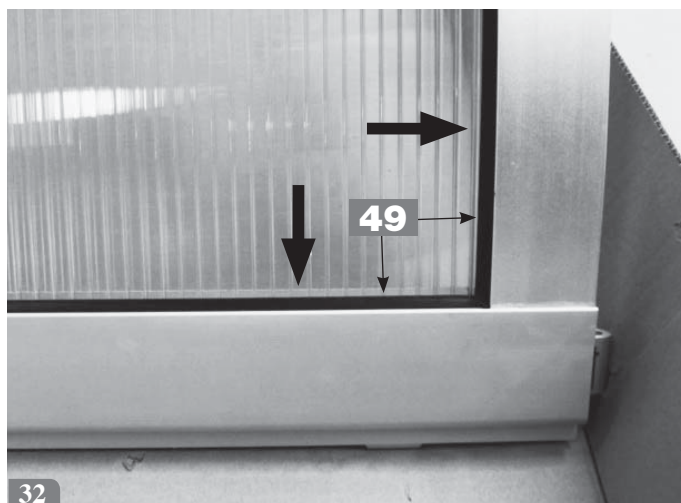
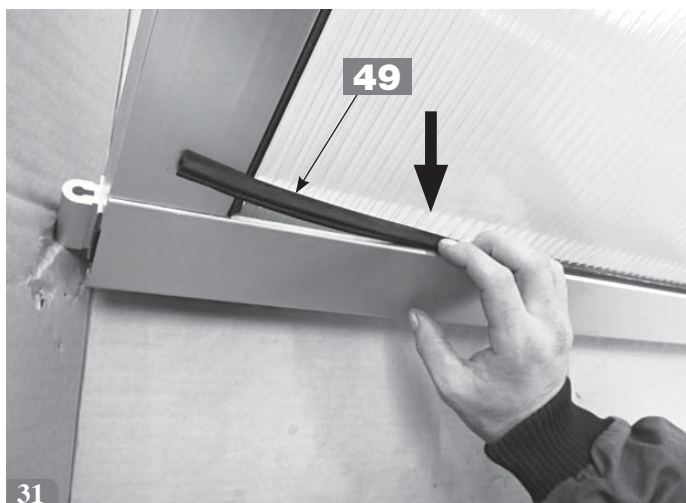

MODULE – without door / MODUL – bez dveří
 MODULE – sans porter / MODULE – zonder deur
 MODULO – senza sportello / MODUL – ohne Tür
 МОДУЛЬ – без дверей / MODUL – utan dörr

TREND

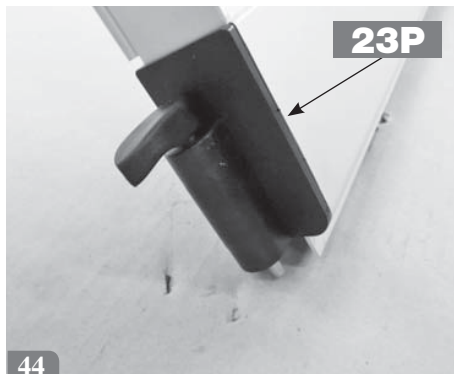
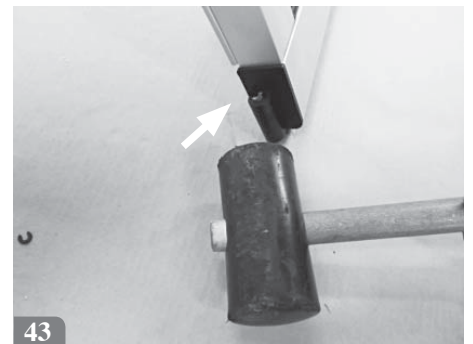
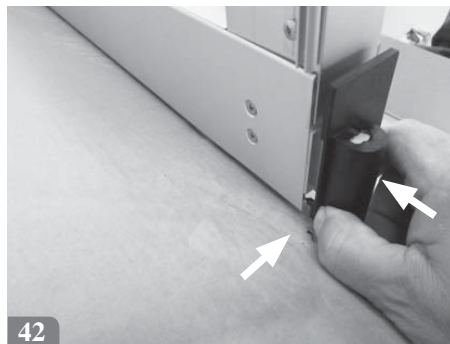
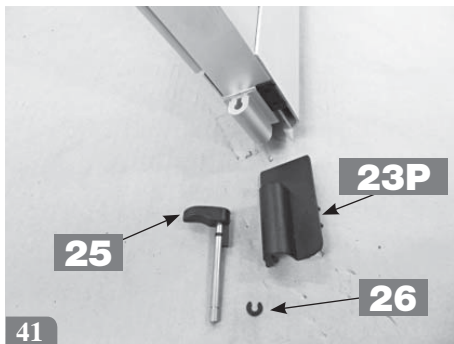
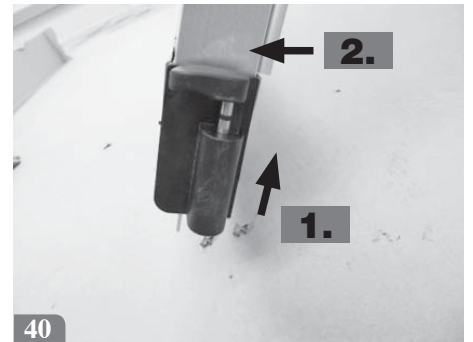
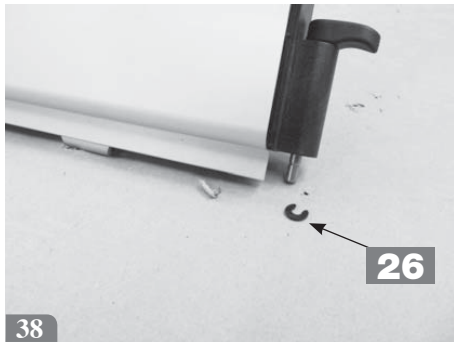

MODULE – without door / MODUL – bez dveří
MODULE – sans porter / MODULE – zonder deur
MODULO – senza sportello / MODUL – ohne Tür
МОДУЛЬ – без дверей / MODUL – utan dörr

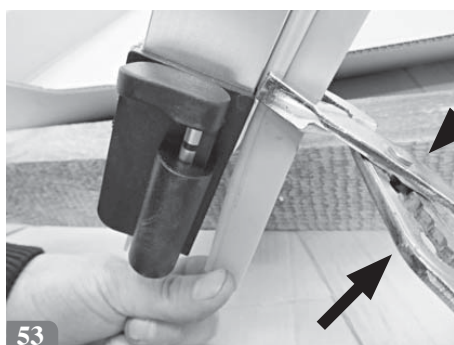
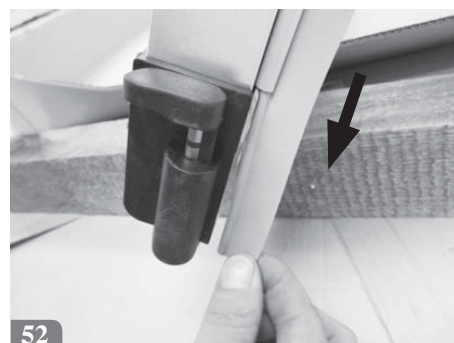
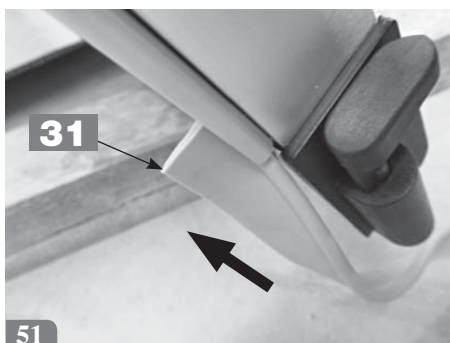

UK All modules without side door are assembled in the same way!

CZ Shodným způsobem skládáme všechny moduly, které nemají boční dveře!

FR Tous les modules n'ayant pas de porte latérale seront montés de façon identique!

NL Op dezelfde manier alle modulen zonder zijdeur samenstellen!

IT Tutti i moduli che non hanno sportello laterale saranno assemblati nello stesso modo!

DE Auf gleiche Weise stellen wir alle Module ohne Seitentür zusammen!

RUS Подобным способом собираем все модули, у которых нет боковых дверей!

SE Sätt ihop alla moduler på samma sätt som inte är försedda med sidodörrar!

MODULE with door / MODUL s dveřmi
 MODULE avec porte / MODULE met deur
 MODULO con sportello / MODUL mit der Tür
 МОДУЛЬ с дверьми / MODUL med dörrar

TREND

UK PARTS

CZ DÍLY

FR PIÈCES

NL DELEN

IT Componenti

DE TEILE

RUS ДЕТАЛИ

SE DELAR



1x 23P



1x 23L

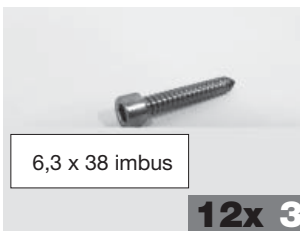

6,3 x 38 imbus

12x 35



4,2x13

8x 10



1x 32



1x 33



2x 22



2x 25

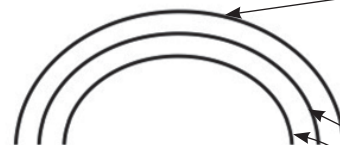

1x **UK** 3 (or 4) - 1
CZ 3 (nebo 4) - 1
FR 3 (ou 4) - 1
NL 3 (of 4) - 1
IT 3 (oppure 4) - 1
DE 3 (oder 4) - 1
RUS 3 (или 4) - 1
SE 3 (eller 4) - 1



31



49

UK ARCHES - MODULE with door
CZ OBLOUKY - MODUL s dveřmi
FR ARCS - MODULE avec porte
NL BOGEN - MODULE met deur
IT ARCHI - MODULO con sportello
DE BÖGEN - MODUL mit der Tür
RUS АРКИ - МОДУЛЬ с дверьми
SE VALV - MODUL med dörrar

1x **UK** 3 (or 4) - S
CZ 3 (nebo 4) - S
FR 3 (ou 4) - S
NL 3 (of 4) - S
IT 3 (oppure 4) - S
DE 3 (oder 4) - S
RUS 3 (или 4) - S
SE 3 (eller 4) - S

1x **UK** 3 (or 4) - 2
CZ 3 (nebo 4) - 2
FR 3 (ou 4) - 2
NL 3 (of 4) - 2
IT 3 (oppure 4) - 2
DE 3 (oder 4) - 2
RUS 3 (или 4) - 2
SE 3 (eller 4) - 2



1x 50

1x 50

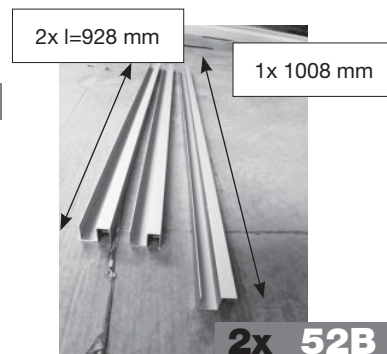

2x l=928 mm

1x 1008 mm

2x 52B

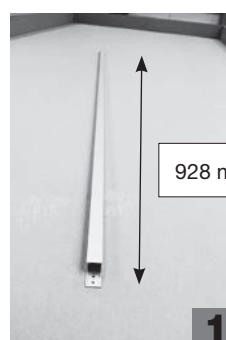

928 mm

1x 55

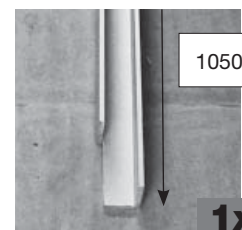

1050 mm

1x 54

UK PC BOARDS

CZ DESKY PC

FR PLAQUES PC

NL PC PLATEN

IT TAVOLE IN PC

DE PC Platte

RUS ЛИСТЫ PC
(поликарбонат)

SE PC-skivor

1x 59

UK 6 mm thick PC board - DOOR

CZ deska PC tl. 6 mm - DVEŘE

FR panneau PC ép. 6 mm - PORTE

NL PC paneel dikte 6 mm - DEUR

IT tavola PC spess. 6mm - SPORTELLLO

DE PC Platte St. 6mm - TÜR

RUS лист PC толщ. 6мм - ДВЕРИ

SE PC-skivan tjockl. 6mm - DÖRR

1x 58

UK 10 mm thick PC board - against the door

CZ deska PC tl. 10mm - proti dveřím

FR panneau PC ép. 10 mm - contre la porte

NL PC paneel - dikte 10 mm - tegen de deur

IT tavola PC spess. 10mm - contro sportello

DE PC Platte St. 10mm - gegen die Tür

RUS лист PC толщ. 10мм - напротив дверям

SE PC-skivan tjockl. 10mm - mittemot dörr

1x 57

UK 10 mm thick PC board - beside the door

CZ deska PC tl. 10mm - vedle dveří

FR panneau PC ép. 10 mm - à côté de la porte

NL PC paneel - dikte 10 mm - naast de deur

IT tavola PC spess. 10mm - accanto sportello

DE PC Platte St. 10mm neben der Tür

RUS лист PC толщ. 10мм - рядом с дверьми

SE PC-skivan tjockl. 10mm - bredvid dörr



UK Before assembly, remove the protective foil from PC boards!

CZ Před montáží nutno odstranit z desek PC ochranné folie!

FR Il est nécessaire avant montage d'enlever les feuilles de protection recouvrant les plaques PC!

NL Voor de montage moeten de PC-bescherfoliën van de panelen verwijderd worden!

IT Rimuovere la pellicola protettiva dalle tavole in PC ancor prima dell'assemblaggio!

DE Vor der Montage muss die Schutzfolie aus den PC-Platten entfernt werden!

RUS Перед сборкой с листов PC (поликарбонатных) надо снять защитную пленку!

SE Ta bort PC-skyddsfolien från skivor innan montering!

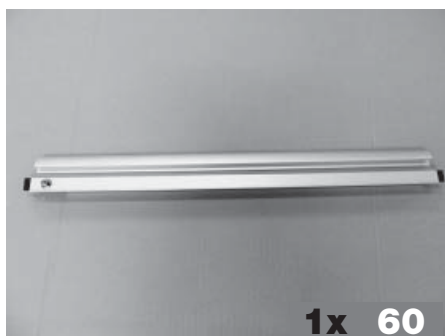

MODULE with door / MODUL s dveřmi
MODULE avec porte / MODULE met deur
MODULO con sportello / MODUL mit der Tür
МОДУЛЬ с дверьми / MODUL med dörrar

TREND

UK For positioning of arches in the module with door see the Appendix to the Assembly Guide (layout diagram)!

CZ Umístění oblouků v modulu s dveřmi viz příloha návodu (schéma)!

FR Se reporter à l'annexe du guide de montage (schéma) pour le positionnement des arcs dans le module avec porte!

NL Het plaatsen van de bogen in de module met de deur - zie bijlage van de handleiding (schema)!

IT Per il posizionamento degli archi nei singoli moduli con sportelli si veda l'Allegato al Libretto d'uso!

DE Lage der Bögen im Modul mit der Tür sieh Anhang der Anleitung (Schema)!

RUS Размещение арок в модуле с дверьми – см. приложение инструкции (схема)!

SE Placering av valv i modul med dörr se bruksanvisning (schema)!

UK Arch Number 3-1-1 (= module number - identification of arch in the module - identification of joint)

CZ Číslo oblouku 3-1-1 (=číslo modulu - označení oblouku v modulu - označení spoje)

FR Numéro de l'arc 3-1-1 (=numéro du module - désignation de l'arc dans le module - désignation de la jonction).

NL Het boognummer 3-1-1 (= modulennr. - markering van de boog in de module - markering van de verbinding)

IT Numero arco 3-1-1 (= numero del modulo - identificazione dell'arco nel modulo - identificazione del giunto)

DE Bogen-Nummer 3-1-1 (= Modulnummer - Bezeichnung des Bogens im Modul - Bezeichnung der Verbindung)

RUS Номер арки 3-1-1 (=номер модуля - обозначение арки в модуле - обозначение соединения)

SE Valvnummer 3-1-1 (=modulnummer - beteckning av valv i modul - beteckning av skarv)

UK ASSEMBLY

CZ SLOŽENÍ

FR COMPOSITION

NL SAMENSTELLING

IT ASSEMBLAGGIO

DE AUFBAU

RUS СОСТАВЛЕНИЕ

SE IHOPSÄTTNING



UK ASSEMBLY OF SIDE DOOR

IT ASSEMBLAGGIO SPORTELLLO LATERALE

CZ SEŠTAVENÍ BOČNÍCH DVEŘÍ

DE ZUSAMMENSETZUNG DER SEITENTÜR

FR MONTAGE DE LA PORTE LATÉRALES

RUS СБОРКА БОКОВЫХ ДВЕРЕЙ

NL MONTAGE VAN DE ZIJDEUR

SE IHOPSÄTTNING AV SIDODÖRR

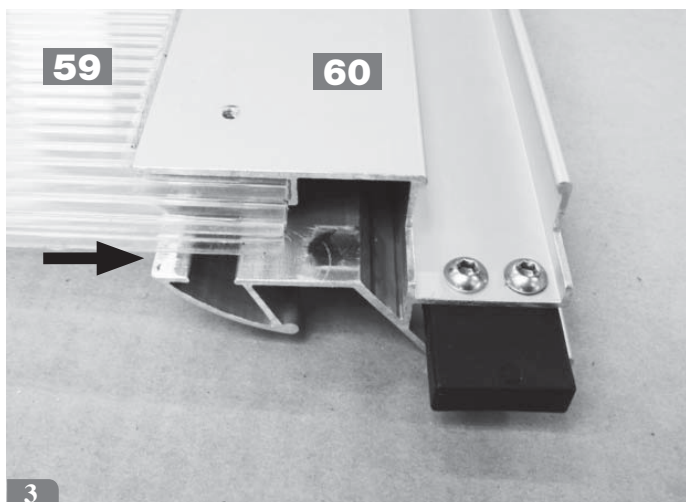
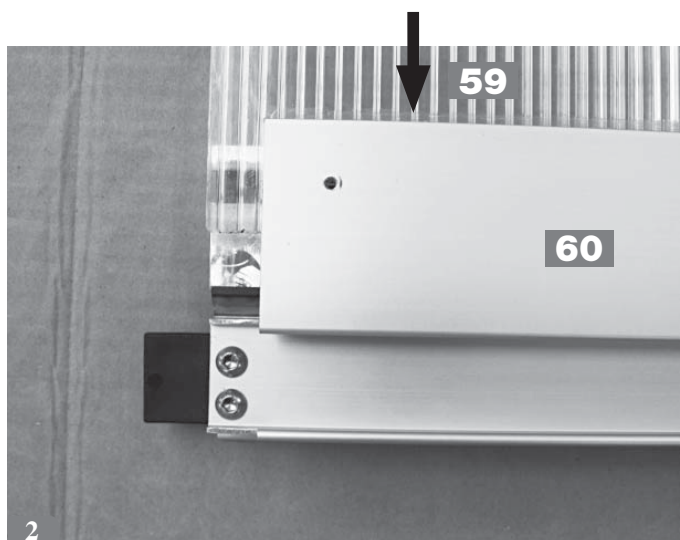
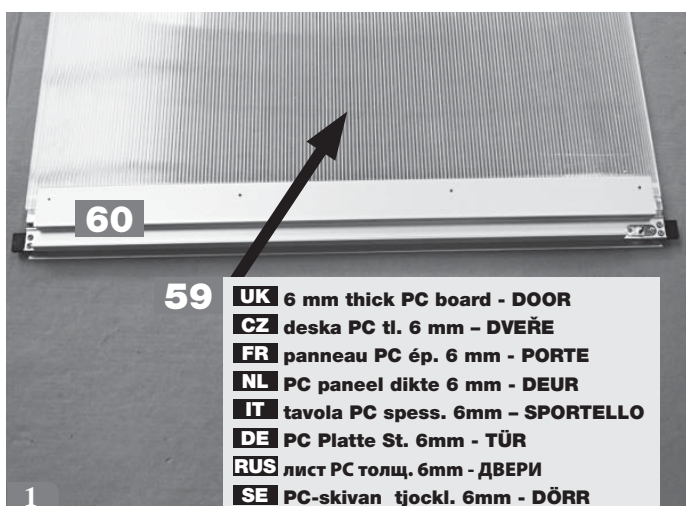

MODULE with door / MODUL s dveřmi
 MODULE avec porte / MODULE met deur
 MODULO con sportello / MODUL mit der Tür
 МОДУЛЬ с дверьми / MODUL med dörrar

TREND

- UK** Before assembly, remove the protective foil from PC boards!
- CZ** Před montáží nutno odstranit z desek PC ochranné folie !
- FR** Il est nécessaire avant montage d'enlever les feuilles de protection recouvrant les plaques PC !
- NL** Voor de montage moeten de PC-beschermfoliën van de panelen verwijderd worden!

- IT** Rimuovere la pellicola protettiva dalle tavole in PC ancor prima dell'assemblaggio!
- DE** Vor der Montage muss die Schutzfolie aus den PC-Platten entfernt werden!
- RUS** Перед сборкой с листов PC (поликарбонатных) надо снять защитную пленку !
- SE** Ta bort PC-skyddsfolien från skivor innan montering!

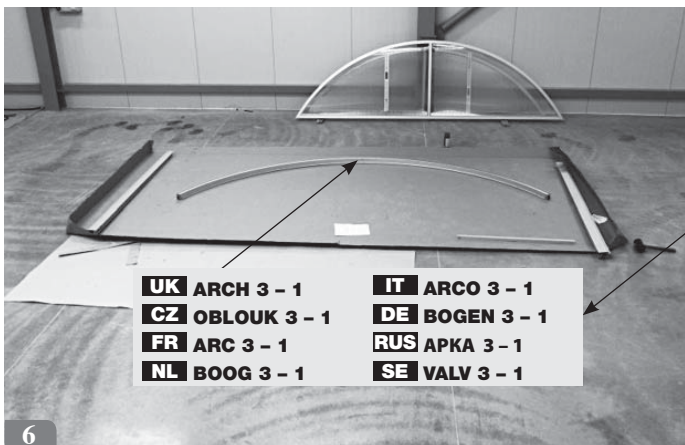

- UK** BETECKNING AV MODUL MED DÖRR 3 eller 4 !
Vi börjar alltid med ett valv längst bort från dörr
- CZ** OZNAČENÍ MODULU S DVEŘMI 3 nebo 4 !
Začínáme vždy obloukem nejvzdálenějším od dveří
- FR** DESIGNATION DU MODULE AVEC LA PORTE 3 ou 4 !
Il faut toujours commencer par l'arc le plus éloigné de la porte
- NL** MARKERING VAN MODULE MET DEUR 3 of 4 !
Altijd met de boog het verst van de deur beginnen
- IT** IDENTIFICAZIONE MODULO CON SPORTELLINO 3 oppure 4 !
Iniziare sempre con l'arco più distante dallo sportello.
- DE** BEZEICHNUNG DES MODULS MIT DER TÜR 3 oder 4 !
Wir beginnen immer mit dem von der Tür äußersten Bogen
- RUS** ОБОЗНАЧЕНИЕ МОДУЛЯ С ДВЕРЬМИ 3 или 4 !
Всегда надо начинать с самой удаленной от дверей арки
- SE** BETECKNING AV MODUL MED DÖRR 3 eller 4 !
Vi börjar alltid med ett valv längst bort från dörr

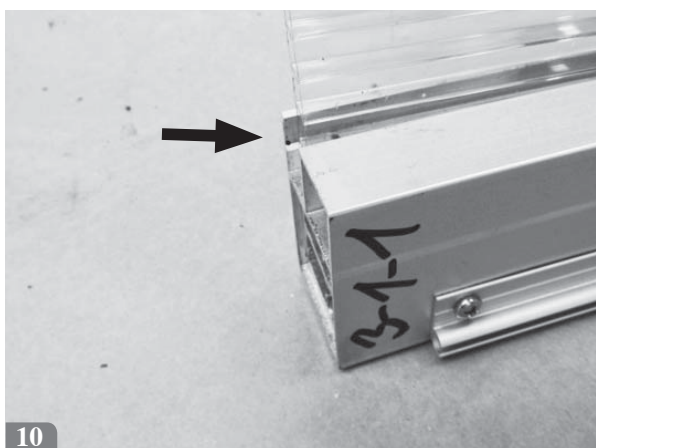
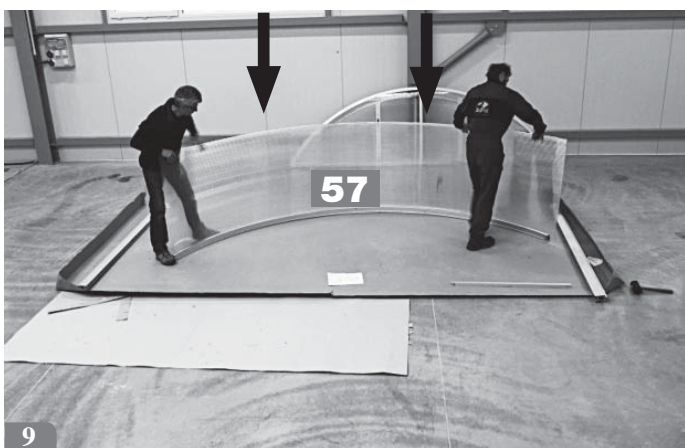
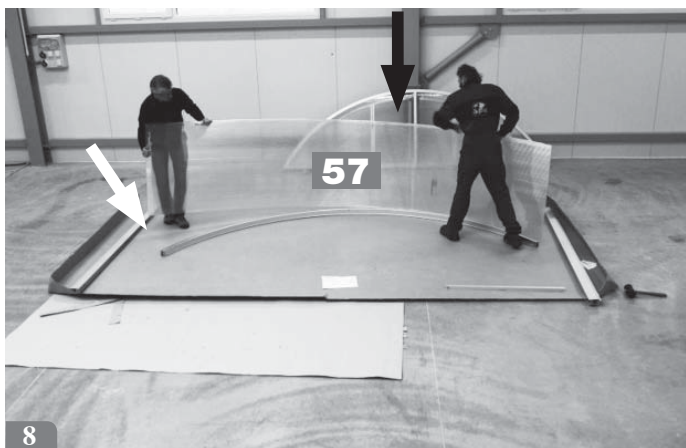
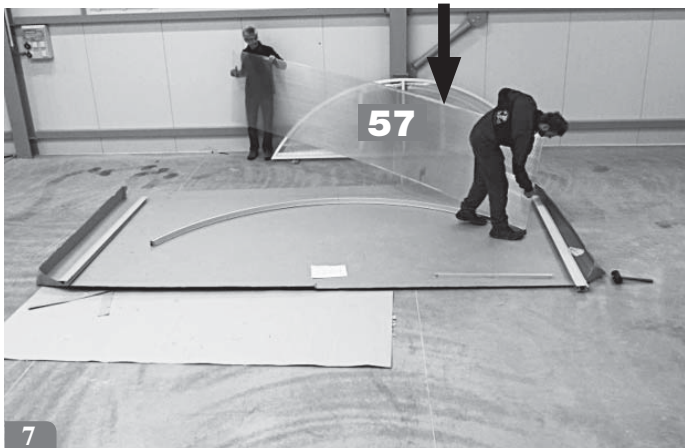

MODULE with door / MODUL s dveřmi
 MODULE avec porte / MODULE met deur
 MODULO con sportello / MODUL mit der Tür
 МОДУЛЬ с дверьми / MODUL med dörrar

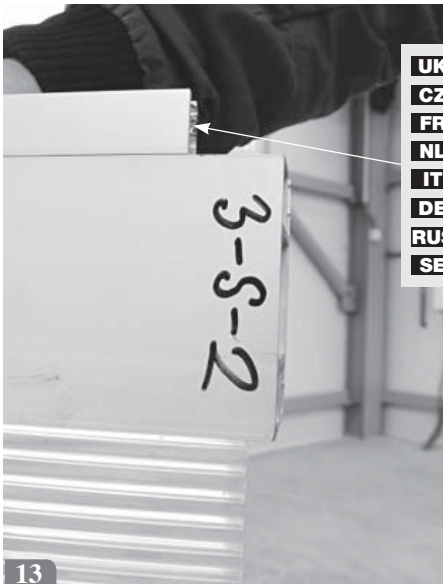
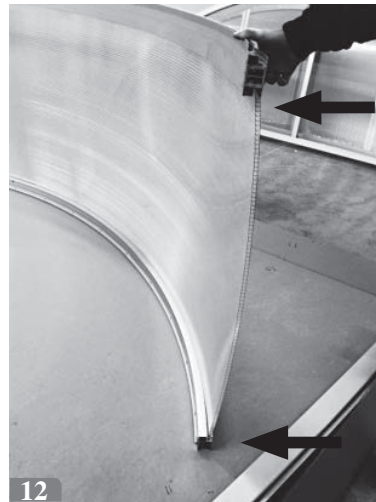
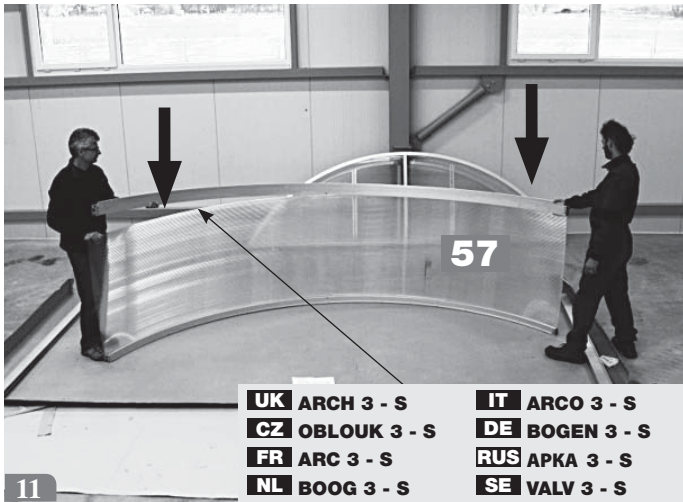

| | |
|------------|------------------------------|
| UK | DOOR SLIDE |
| CZ | DRÁHA DVEŘÍ |
| FR | CHEMIN DE LA PORTE |
| NL | BAAN VAN DE DEUR |
| IT | DIREZIONE APERTURA SPORTELLO |
| DE | TÜR-SPUR |
| RUS | ПУТЬ ДВЕРЕЙ |
| SE | DÖRRENS BANAN |

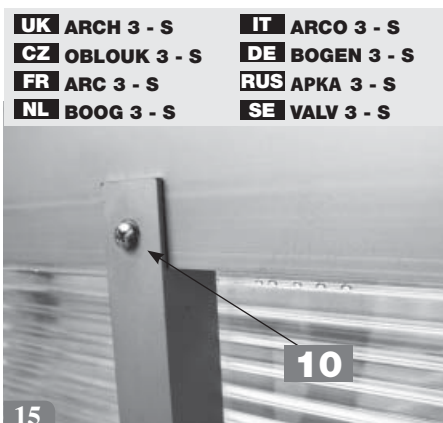

MODULE with door / MODUL s dveřmi
 MODULE avec porte / MODULE met deur
 MODULO con sportello / MODUL mit der Tür
 МОДУЛЬ с дверьми / MODUL med dörrar

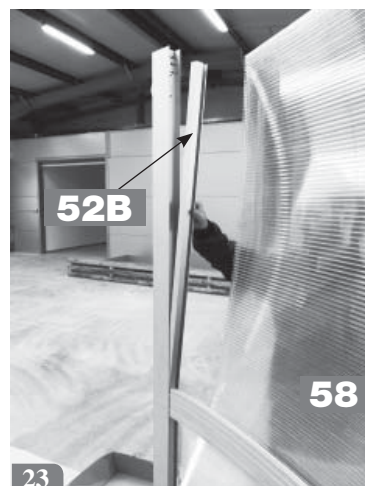
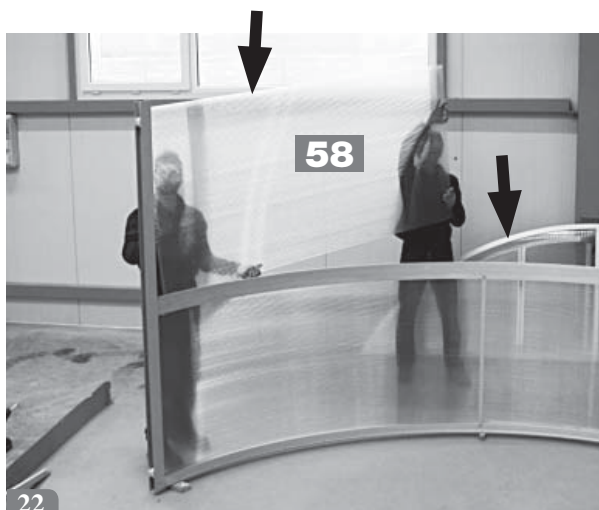
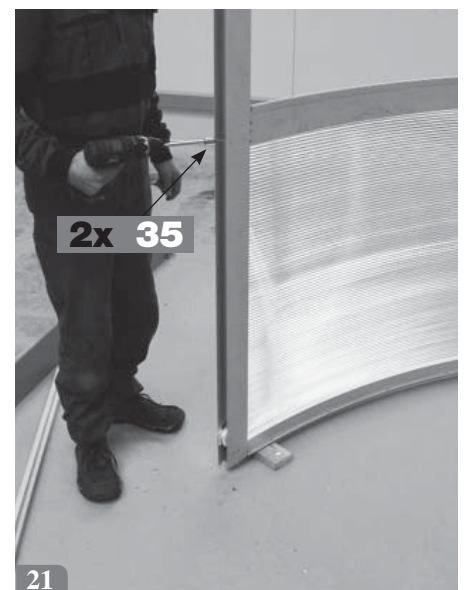
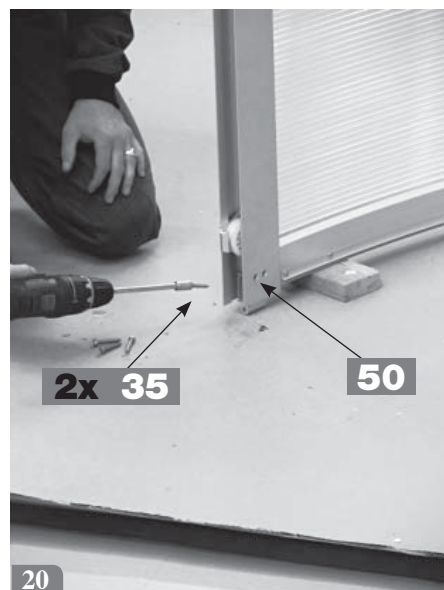
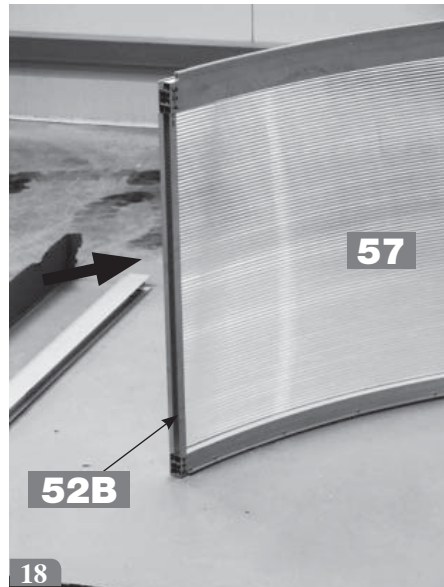
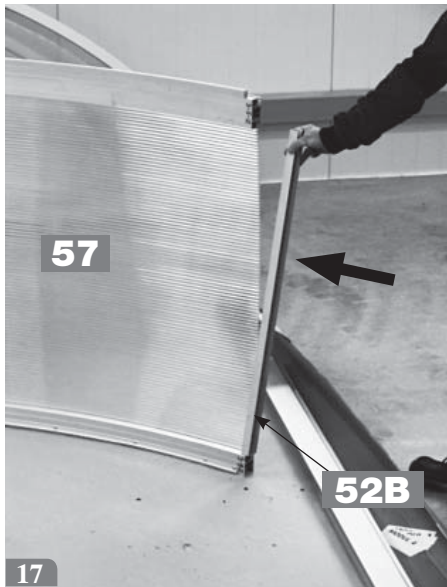

MODULE with door / MODUL s dveřmi
 MODULE avec porte / MODULE met deur
 MODULO con sportello / MODUL mit der Tür
 МОДУЛЬ с дверьми / MODUL med dörrar

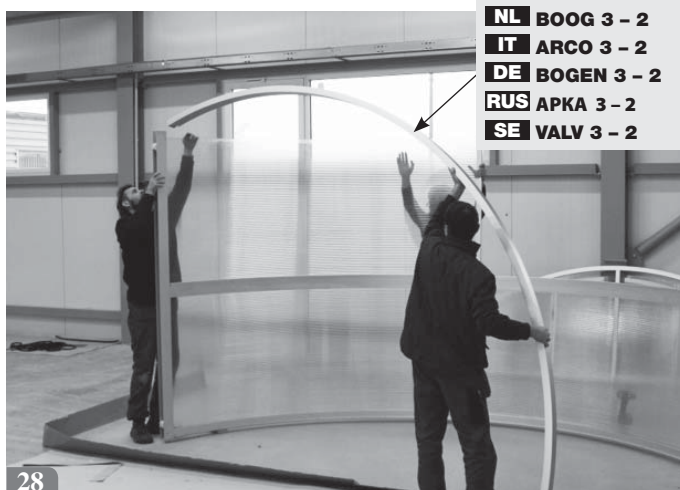
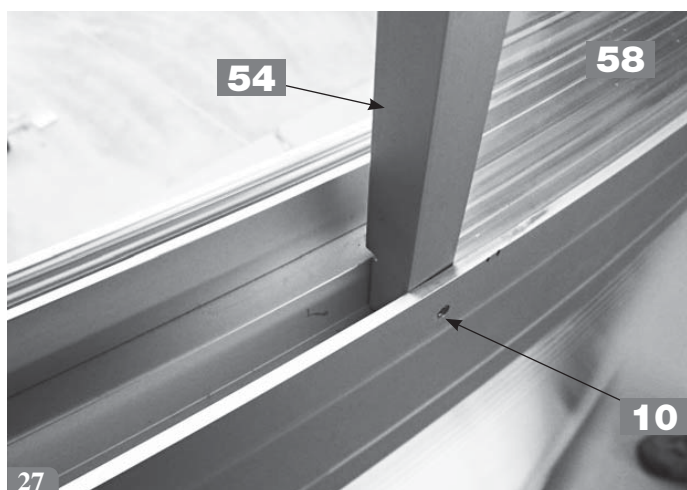
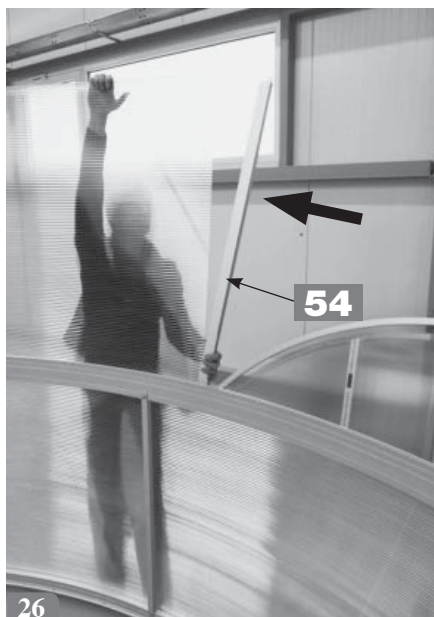

- UK** ARCH 3 - 2
- CZ** OBLOUK 3 - 2
- FR** ARC 3 - 2
- NL** BOOG 3 - 2
- IT** ARCO 3 - 2
- DE** BOGEN 3 - 2
- RUS** АРКА 3 - 2
- SE** VALV 3 - 2



MODULE with door / MODUL s dveřmi
MODULE avec porte / MODULE met deur
MODULO con sportello / MODUL mit der Tür
МОДУЛЬ с дверьми / MODUL med dörrar

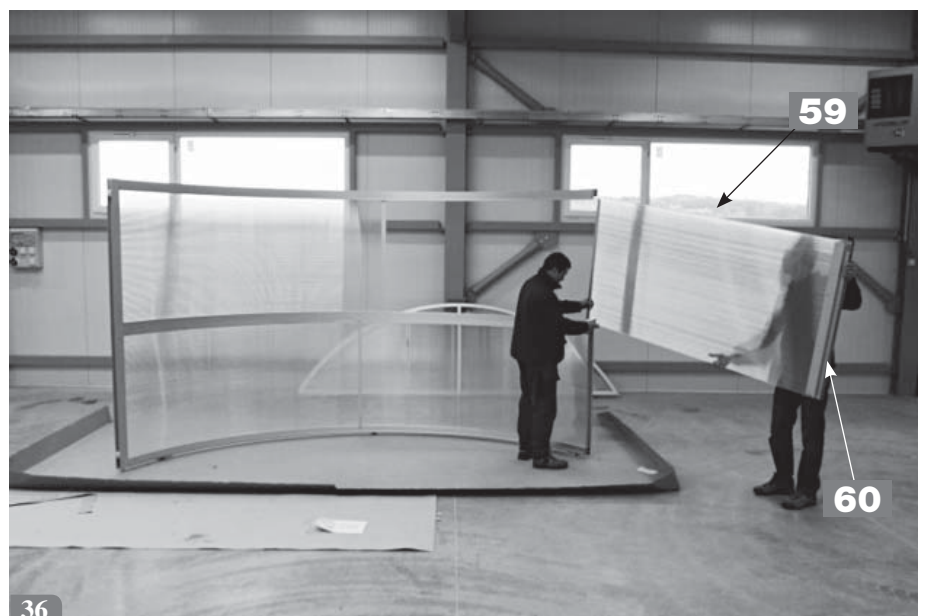
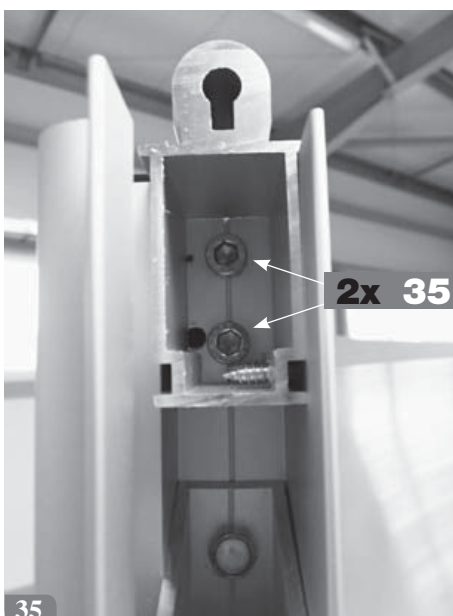

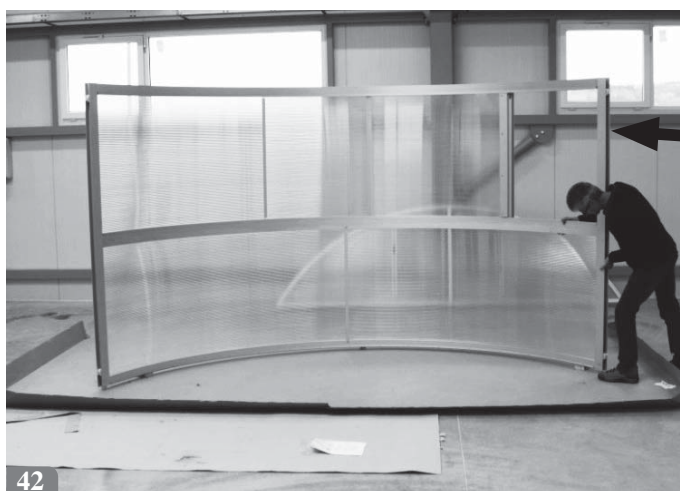
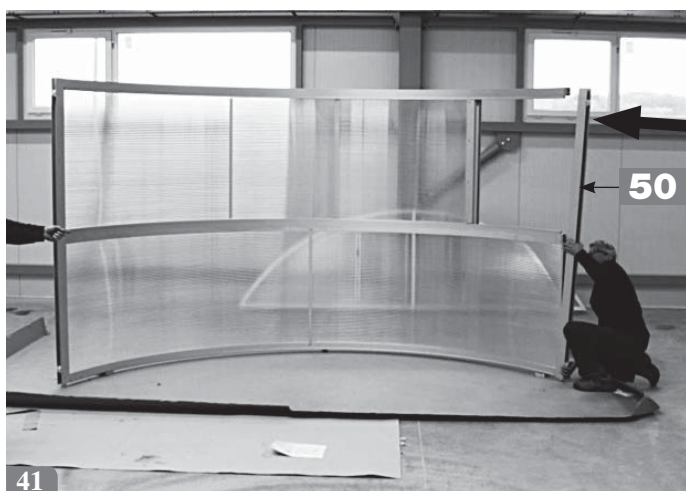
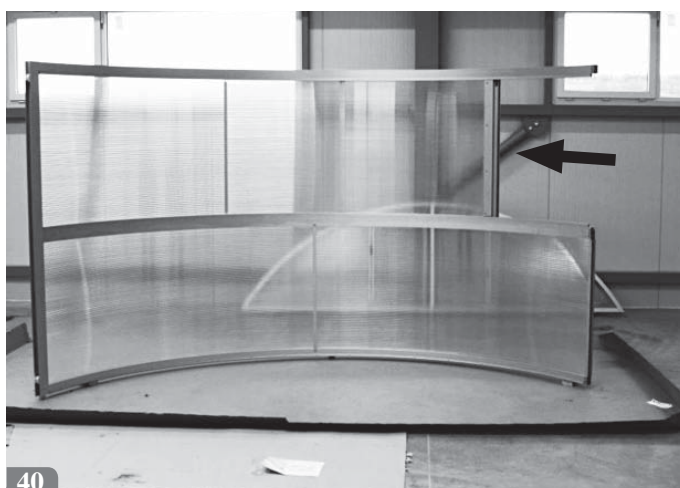
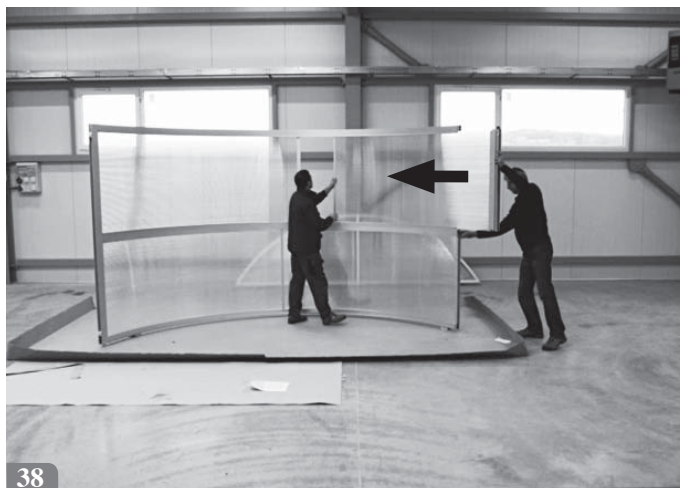

MODULE with door / MODUL s dveřmi
MODULE avec porte / MODULE met deur
MODULO con sportello / MODUL mit der Tür
МОДУЛЬ с дверьми / MODUL med dörrar

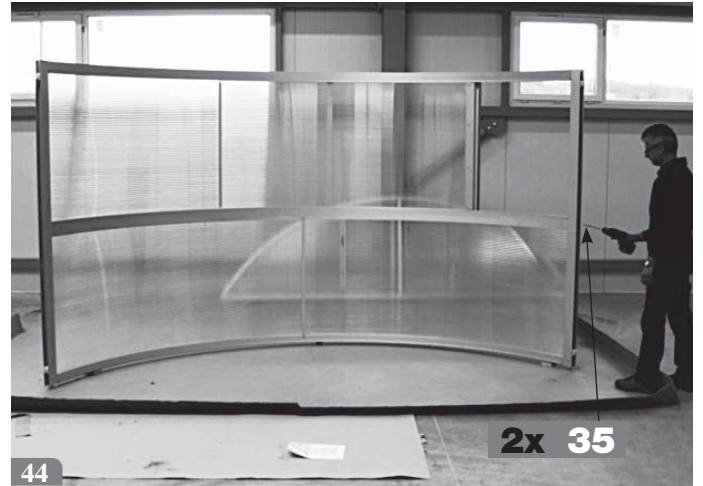
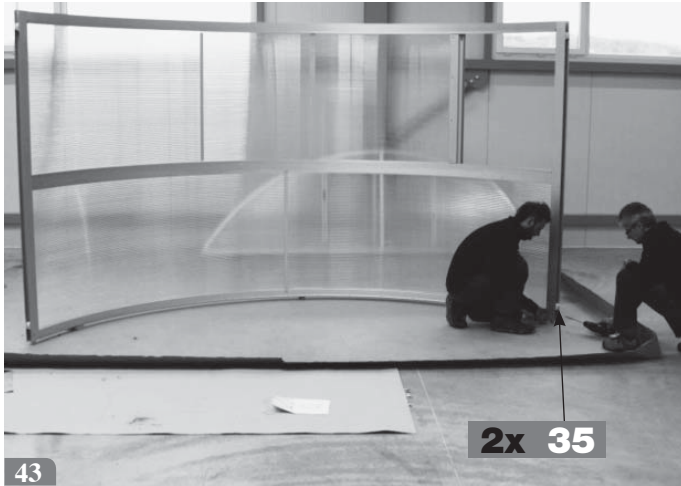

MODULE with door / MODUL s dveřmi
MODULE avec porte / MODULE met deur
MODULO con sportello / MODUL mit der Tür
МОДУЛЬ с дверьми / MODUL med dörrar

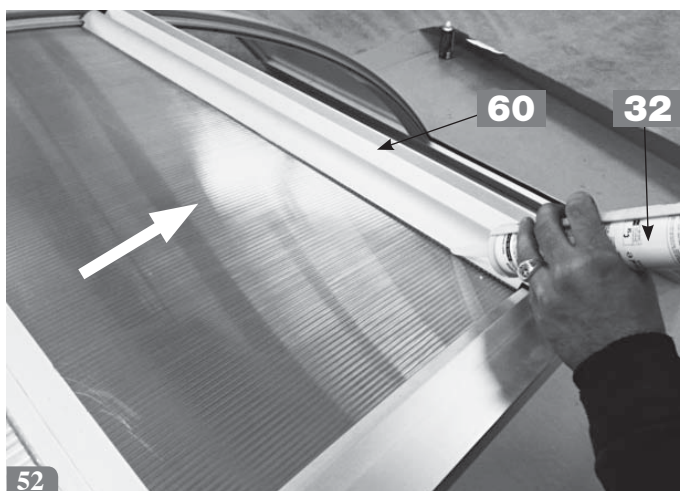
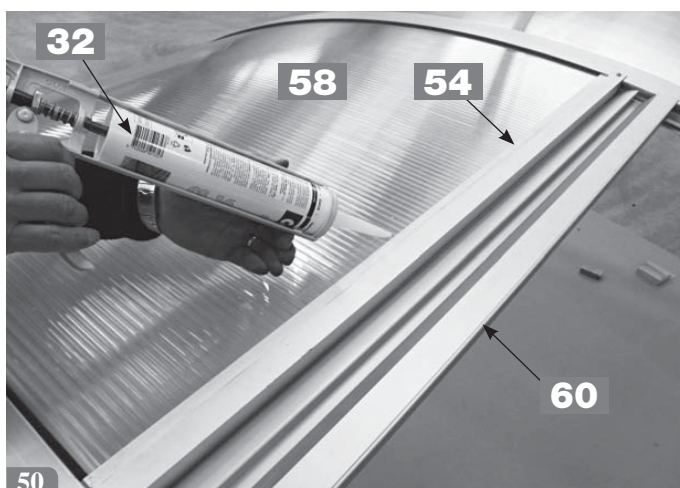
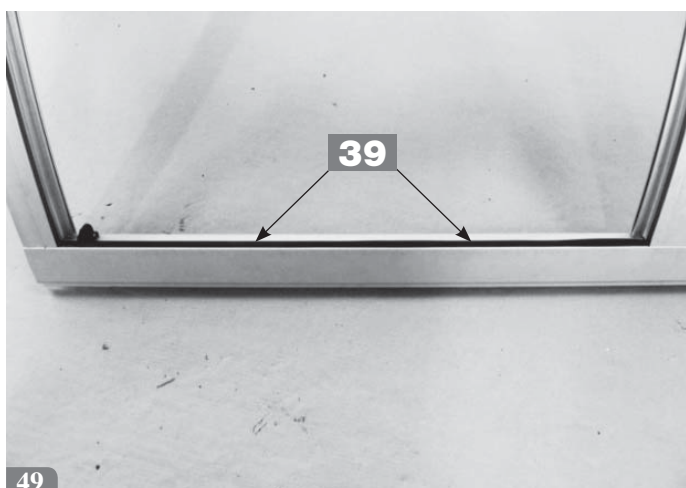
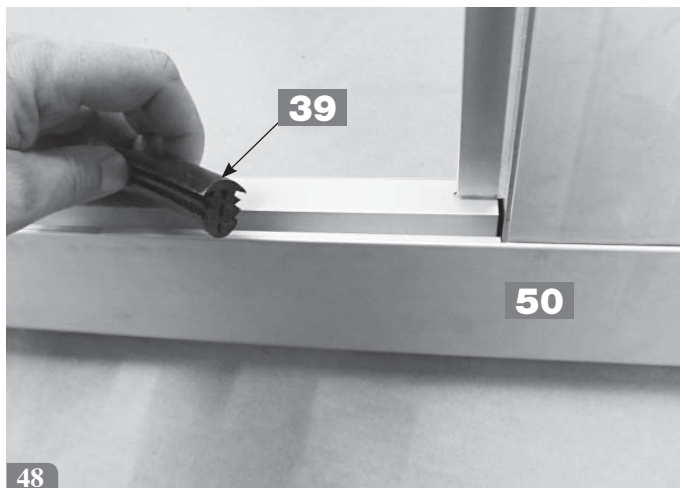

MODULE with door / MODUL s dveřmi
MODULE avec porte / MODULE met deur
MODULO con sportello / MODUL mit der Tür
МОДУЛЬ с дверьми / MODUL med dörrar

TREND

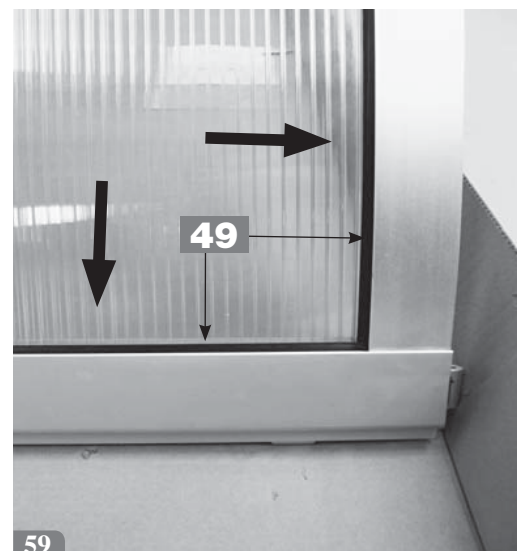
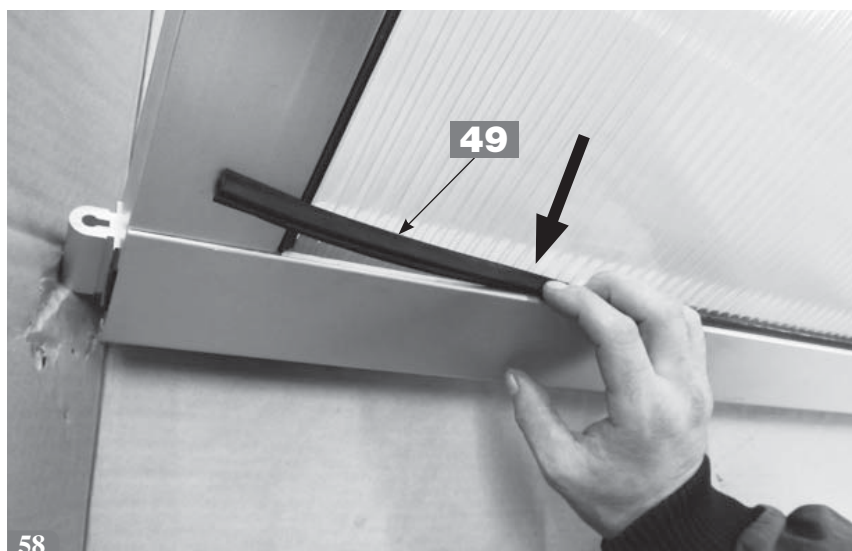
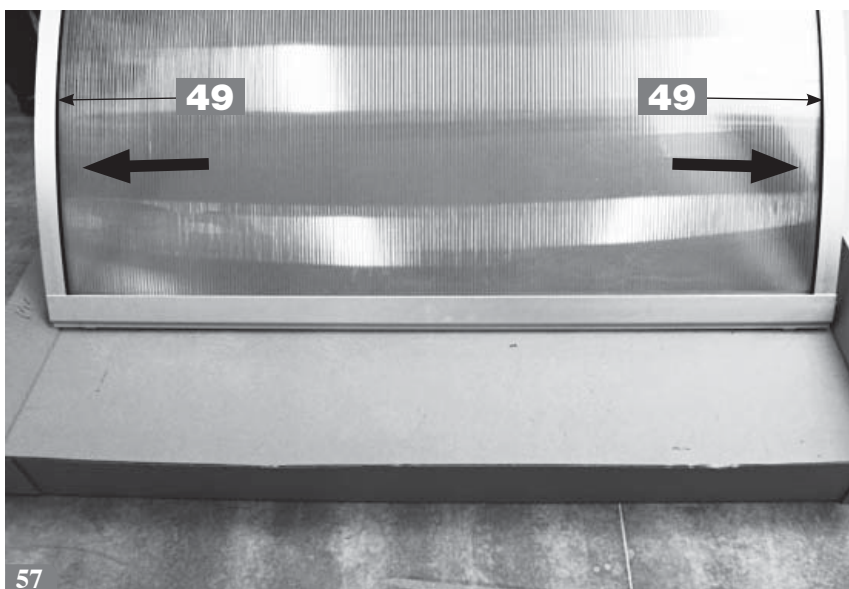
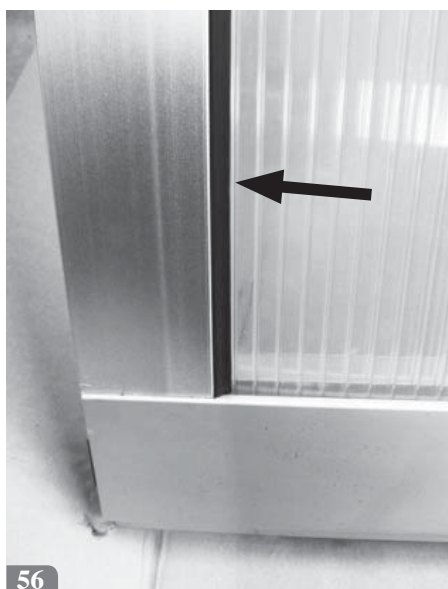
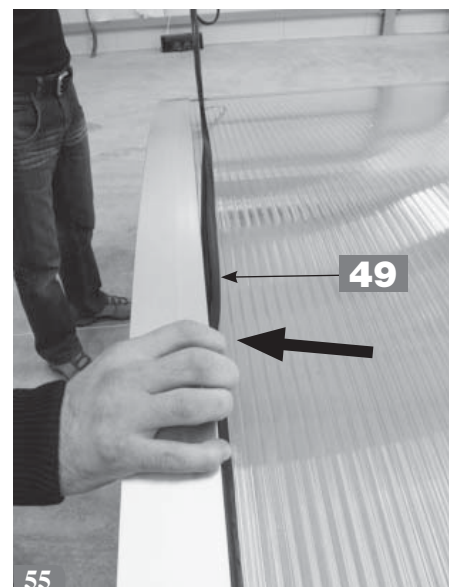
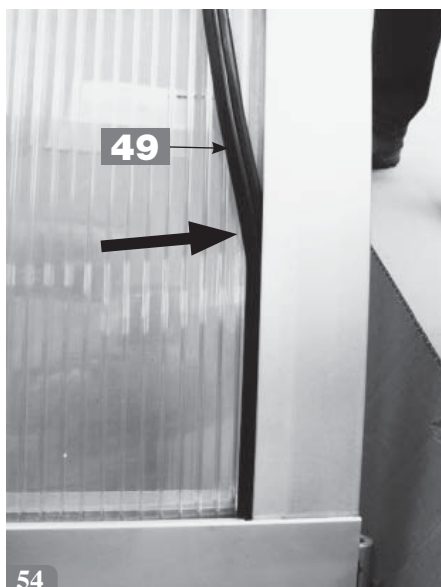
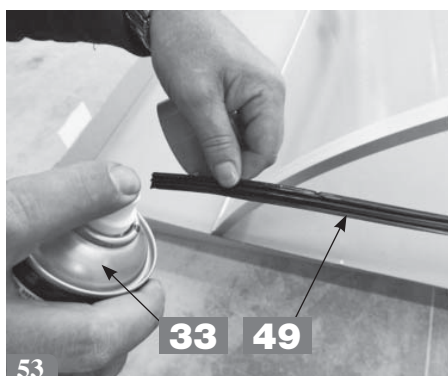

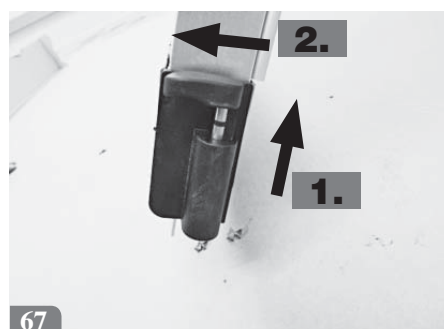
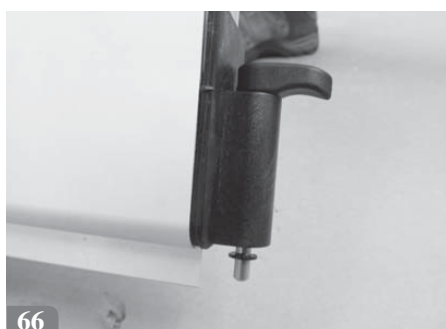
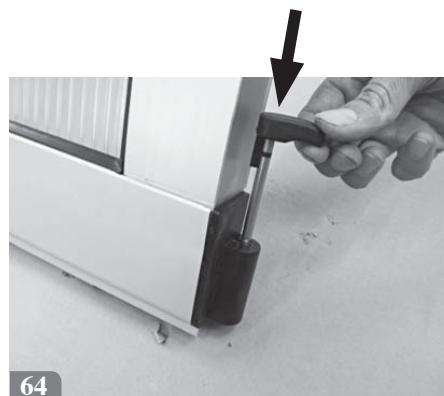
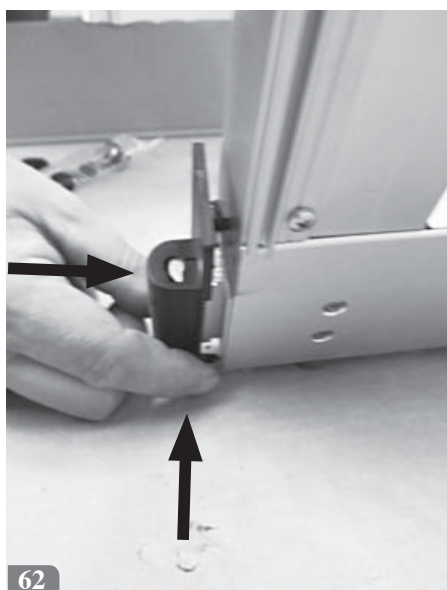
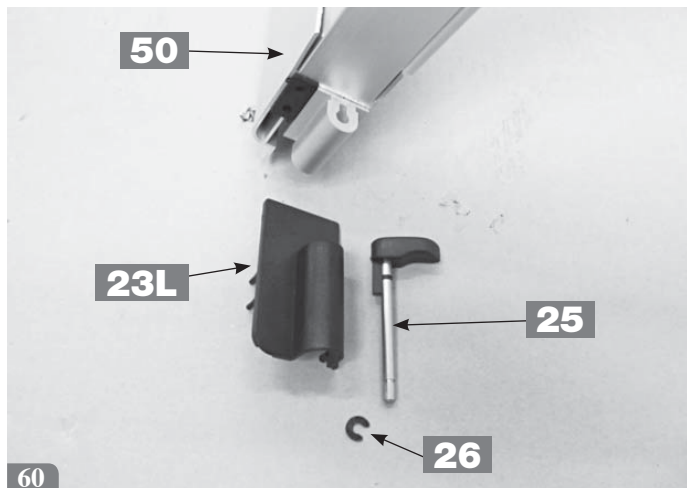

MODULE with door / MODUL s dveřmi
MODULE avec porte / MODULE met deur
MODULO con sportello / MODUL mit der Tür
МОДУЛЬ с дверьми / MODUL med dörrar

TREND

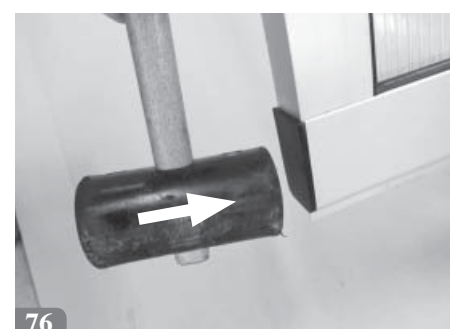
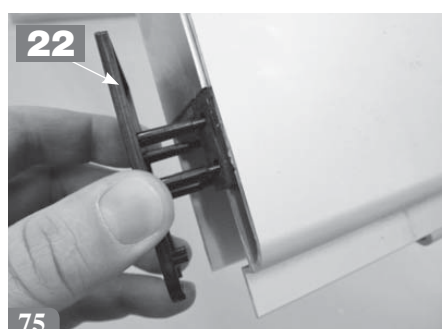
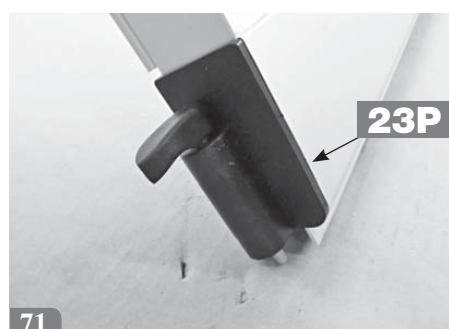
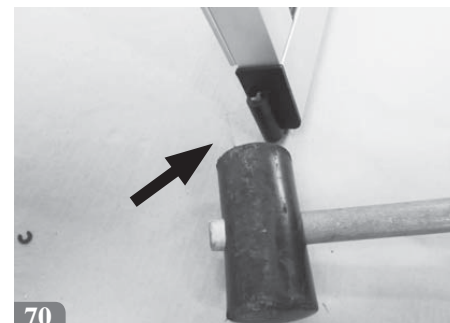
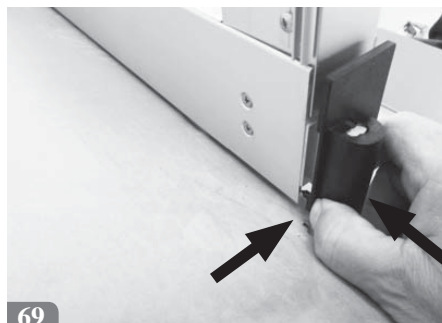
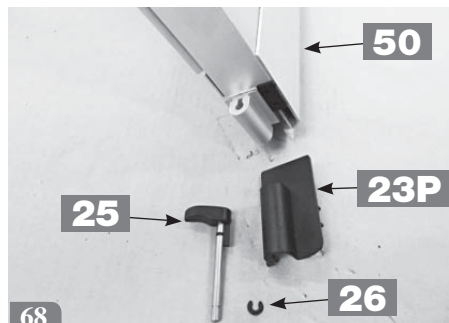

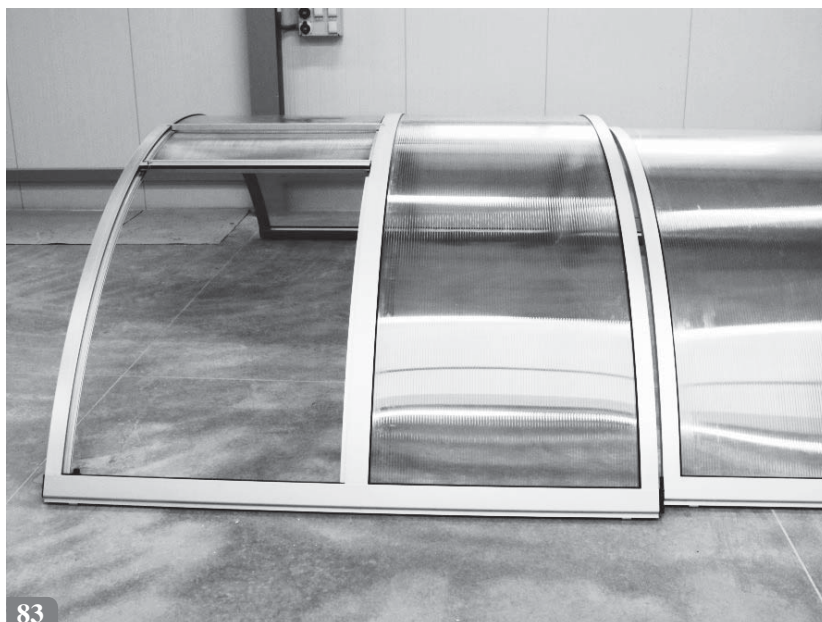
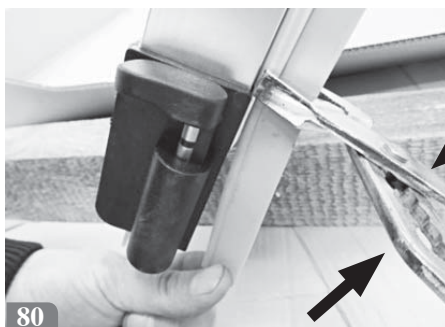
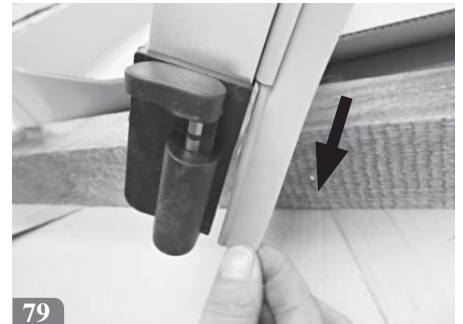
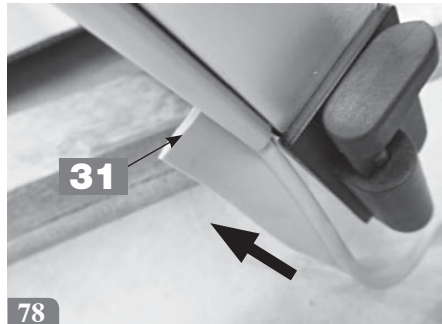

MODULE with door / MODUL s dveřmi
MODULE avec porte / MODULE met deur
MODULO con sportello / MODUL mit der Tür
МОДУЛЬ с дверьми / MODUL med dörrar

TREND

UK For positioning of arches in the module with door see the Appendix to the Assembly Guide (layout diagram)!

CZ Umístění oblouků v modulu s dveřmi viz příloha návodu (schéma) !

FR Se reporter à l'annexe du guide de montage (schéma) pour le positionnement des arcs dans le module avec porte !

NL Het plaatsen van de bogen in de module met de deur - zie bijlage van de handleiding (schema)!

IT Per il posizionamento degli archi nei singoli moduli con sportelli si veda l'Allegato al Libretto d'uso!

DE Lage der Bögen im Modul mit der Tür sieh Anhang der Anleitung (Schema) !

RUS Размещение арок в модуле с дверьми – см. приложение инструкции (схема) !

SE Placering av valv i modul med dörr se bruksanvisning (schema) !

UK Arch Number 3-1-1 (= module number - identification of arch in the module - identification of joint)

CZ Číslo oblouku 3-1-1 (=číslo modulu - označení oblouku v modulu - označení spoje)

FR Numéro de l'arc 3-1-1 (=numéro du module - désignation de l'arc dans le module - désignation de la jonction).

NL Het boognummer 3-1-1 (= modulennr. - markering van de boog in de module - markering van de verbinding)

IT Numero arco 3-1-1 (= numero del modulo - identificazione dell'arco nel modulo - identificazione del giunto)

DE Bogen-Nummer 3-1-1 (= Modulnummer - Bezeichnung des Bogens im Modul - Bezeichnung der Verbindung)

RUS Номер арки 3-1-1 (=номер модуля - обозначение арки в модуле - обозначение соединения)

SE Valvnummer 3-1-1 (=modulnummer - beteckning av valv i modul - beteckning av skarv)

Mailing address

Mountfield, a.s.
Mirošovická 697
251 64 Mnichovice u Prahy
Czech Republic

Head Office

Mountfield, a.s.
Všechromy 56/Highway D1, exit 15
251 63 Strančice
Czech Republic

Contacts

Tel: +420 255 704 261
Fax: +420 255 704 263
email: export@mountfield.cz
www.mountfield-export.com



Czech

ČSN EN ISO 9001:2009

Mountfield